

Improving Power Quality and Fault Ride-Through (FRT) in Grid-Connected Hybrid Energy Systems: Design and Optimization of Dynamic Voltage Restorers

Vardhan Patidar

MTech Scholar

Department of Electrical Engineering

Bhabha University

Bhopal, Madhya Pradesh, India

ashi.sonali12@gmail.com

Ashish Bhargava

Assistant Professor

Department of Electrical Engineering

Bhabha University

Bhopal, Madhya Pradesh, India

Abstract: The integration of renewable energy sources (RESs) into grid-connected systems has become pivotal in addressing climate change and building a sustainable, carbon-neutral society. However, challenges like power quality issues, grid stability, and fault ride-through (FRT) requirements remain significant. This study explores strategies to enhance FRT capabilities and improve power quality in hybrid energy systems. It emphasizes the role of advanced devices such as Dynamic Voltage Restorers (DVRs), EV charging stations, and energy storage solutions. The effectiveness of these technologies is analyzed under various fault scenarios, highlighting improvements in transient response, voltage stability, and harmonic reduction. Additionally, hybrid energy systems, combining multiple RESs and backup sources, are proposed as viable solutions to address intermittency and system reliability. MATLAB/SIMULINK simulations validate the proposed approaches, showcasing their effectiveness in mitigating grid disturbances and maintaining operational efficiency. The findings underline the importance of innovative control strategies and hybrid configurations in ensuring a resilient and sustainable energy infrastructure.

Keywords: Renewable Energy, Fault Ride-Through, Power Quality, Hybrid Energy Systems, Dynamic Voltage Restorer, Grid Stability.

I. INTRODUCTION

In order to address the problem of climate change and pave the way for the development of a carbon-neutral society,

increased usage of renewable energy sources (RESs), such as wind and photovoltaic solar, has gained prominence recently. By integrating the RESs into the power grid through grid-tied converters, the characteristics of the conventional power grid are changed [1]. The need to lessen the harsh effects of climate change, which result in a dramatic rise in distributed energy resources (DERs) from renewable sources at the lower voltage levels of the systems, as well as the empowerment of citizens as active energy producers and consumers, are the driving forces behind this change. These include using electric vehicles (EVs) as distributed storage or storing excess energy output by creating and supplying networks of hydrogen gas. As DERs multiply and passive distribution networks become more active, the entire energy chain—from microgrids to distribution management systems (DMSs), smart cities, smart homes, active consumers, and centralized energy management systems (EMSs) at the transmission system level—shares operational decisions. [2].

In order to offer low-carbon energy and support sustainable development, hybrid energy systems that integrate renewable energy sources with zero emissions with natural gas-powered combination cooling, heating, and power (CCHP) technologies with high energy efficiency are thought to be an efficient solution. Due to their easy use and advanced technology, solar and geothermal resources have emerged as the most advantageous options when it comes to renewable resources.

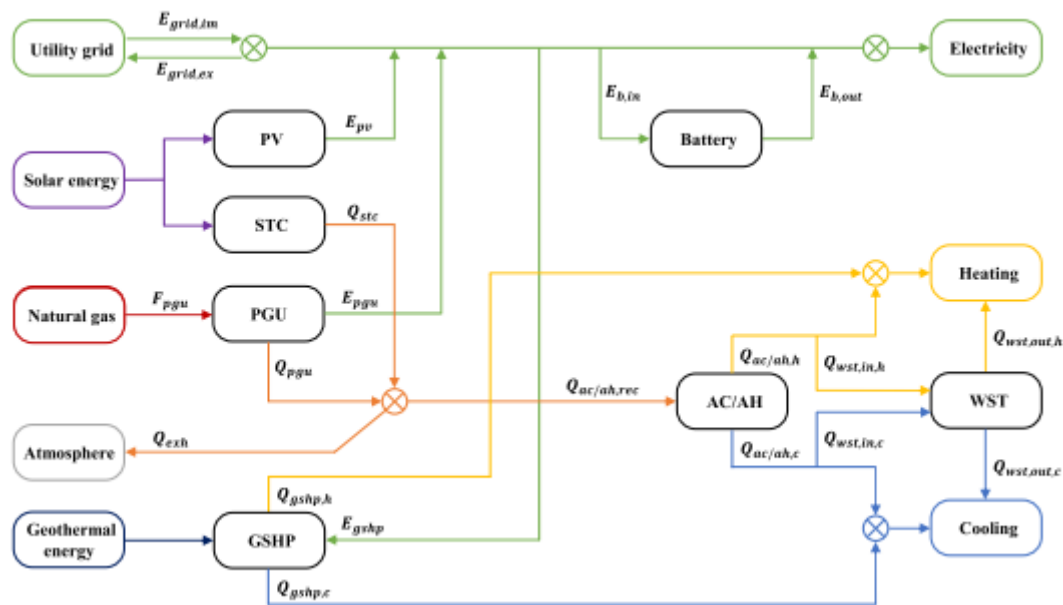

Fig.1 The schematic diagram of hybrid energy system [3]

Hydropower, nuclear power, and the so-called new renewables—primarily solar and wind power—are the principal substitutes for fossil fuels in the electrical industry. Both solar and wind power are extremely erratic and must be paired with energy storage or other more reliable power sources, whereas nuclear and hydropower are reliable power sources that can support a sizable base load. Due to its limited geographic reach, hydropower will not be a viable option in many regions of the world. Although many coal and natural gas facilities may theoretically be replaced by nuclear power, most nations are actually reducing their nuclear power capacity because of concerns about safety, waste storage, costs, and social opposition. The most practical substitute for fossil fuels in many parts of the world is solar and/or wind power, which necessitates extensive energy storage for incorporating significant amounts of renewable energy into power networks [4].

Electric power grid operators, equipment manufacturers, international code agencies, and consumers should all establish the various definitions, ranges, and criteria that make up power quality phenomena. Poor power quality can lead to increased energy use as well as unintended costs such as device damage, data loss, and equipment failure. The annual cost is estimated to be between USD 119 and USD 188 billion for U.S. firms and EUR 150 billion for the European sector. Since then, the main objective of power quality standards has been to regulate the quality of electrical energy, which must meet the requirements of a particular electrical system.

Consequently, many organizations put forth differing definitions of power quality [5]. High-quality current can be added to the grid from the grid-connected PV system by properly controlling the interacting power converters. However, it should be noted that the grid is usually not a perfect sinusoidal voltage or that it may be difficult to maintain its quality at a consistent frequency and amplitude. The many grid events and disturbances, including sag, swell, transients/spikes, harmonics, unbalance, flicker, frequency fluctuations, and outages, are listed in Figure 2. These may result in increased power loss for adjacent equipment or jeopardize the stability of the entire system, as in the case of voltage transient faults. Therefore, it is necessary to build advance control for the PV system in uncommon situations.

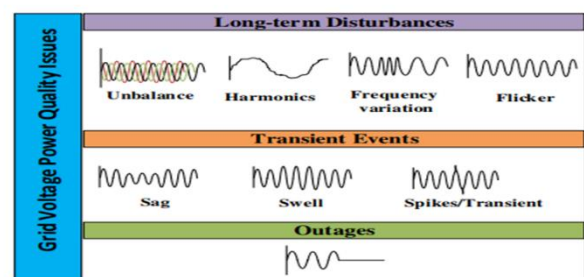

Fig. 2 Typical grid-voltage power quality issues [6]

II. DIFFERENT ENERGY SYSTEMS IN GRID

2.1 Hydropower

The largest renewable energy source in the world, hydropower provides around 16% of the world's electricity needs. In more than 35 countries, hydropower provides at least half of the country's electricity needs. In Bhutan, the

Democratic Republic of the Congo, Ethiopia, Lesotho, Mozambique, Nepal, Norway, Paraguay, Zambia, and the Canadian province of Quebec, hydropower accounts for over 90% of electricity generation (World Bank, 2015). Since 2015, the average annual growth rate of the world's hydropower capacity has been 2.1%. According to the International Hydropower Association, an extra 80–100

million metric tons of carbon would have been released if the energy produced by hydropower in 2019 had been produced by burning coal instead. According to the International Renewable Energy Agency, 850 GW of additional hydropower capacity will be required by 2050 in order to keep the increase in global temperatures over preindustrial levels to less than 2°C [7].

2.2 Solar Power

Active and passive technologies make up the entirety of the solar energy harvesting idea. While the active solar system absorbs solar radiation, the passive technology gathers solar electricity without converting thermal or light energy. For the active solar system to transform solar energy into heat and power, it needs electrical and mechanical components, such as fans or pumps. Photovoltaic (PV) and concentrated

solar power (CSP) are two categories of active solar power technologies. The IRENA roadmap projects that, from its current supply of roughly 3%, solar PV power output will account for 13% of global power generation by 2030 and 25% by 2050. Additionally, solar energy will reduce the cost of fossil fuels and lessen the rising dependency on foreign energy sources. However, solar energy must be profitable in order to gain traction. Consequently, improving solar energy conversion efficiency is a common problem, mostly because of technological limitations [8]. In photovoltaic (PV) power technology, the semiconductor cells, or wafers, are usually many square centimetres in size. According to solid-state physics, the cell is basically a large area p-n diode with the junction close to the top surface. The cell converts sunlight into direct current power. The number of cells assembled in a module to generate the required power is shown in Figure 3.

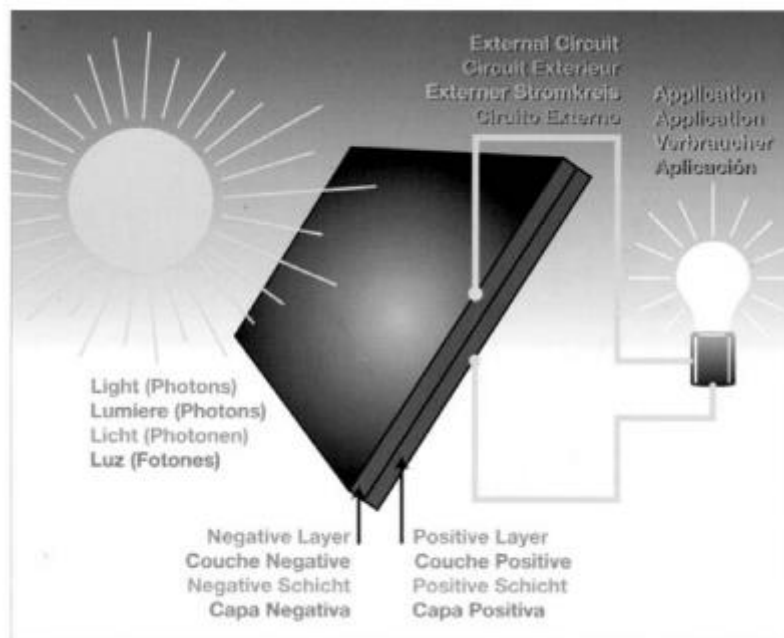

Fig.3 Photovoltaic module in sunlight generates direct current electricity [9]

2.3 Wind Power

- Technically and economically, wind energy is the most promising and widely available renewable energy source. Its large industrial scale, high energy conversion rate, and the substantial social benefits are its advantages. According to the Global Wind Energy Council (GWEC), the top nations with around 73% of the world's installed wind power capacity—650 GW in 2019—are China, the United States, Germany, India, and Spain. To date, wind have employed three versions of wind turbines:
 - A squirrel cage induction generator (SCIG)-based fixed-speed wind turbine that is directly connected to the grid.
 - Variable speed wind turbine based on a doubly fed induction generator (DFIG), in which the stator winding is directly connected to the grid and the rotor winding is connected to the grid via a converter.
 - Direct-drive wind turbine with variable speed and permanent magnet synchronous generator (PMSG), with a variable frequency power electronics converter connecting to the grid. Because this kind of structure eliminates the need for gearboxes, it has enhanced energy capture capacity, increased system dependability and efficiency, and reduced costs [10].
- According to the Paris Agreement, two-thirds of the world's energy needs must be met by renewable sources by 2050 in order to keep the global temperature increase below 2 °C. Wind energy has grown in popularity among all forms of renewable energy sources, including solar photovoltaic, tidal, waves, and contemporary bioenergy, due to its high efficiency, affordability, and environmental benefits. Furthermore, wind energy is a major contributor to the renewable energy sector's electricity production because of its abundance. Over the past ten years, it has experienced the highest growth and demand of any renewable energy source.

According to recent studies, installed wind power capacity increases by about 30% annually. However, because wind speed and direction fluctuate so much, the electricity produced by wind turbines varies quickly. Additionally, it depends on the date, time of day, humidity, and topography. Distribution networks, where a balance between power supply and demand is strongly sought, find wind power management difficult due to this ongoing change [11].

Biomass is the energy source that makes up the majority of renewable energy. Bioenergy accounted for 12.4% of total final energy consumption in 2017. 50% of the renewable energy used in 2017 came from modern bioenergy, excluding the conventional use of biomass. Bioenergy will continue to be the energy source with the fastest rate of development in the use of renewable energy in the foreseeable future, specifically in the years 2018–2023 [12].

2.4 Biomass Energy

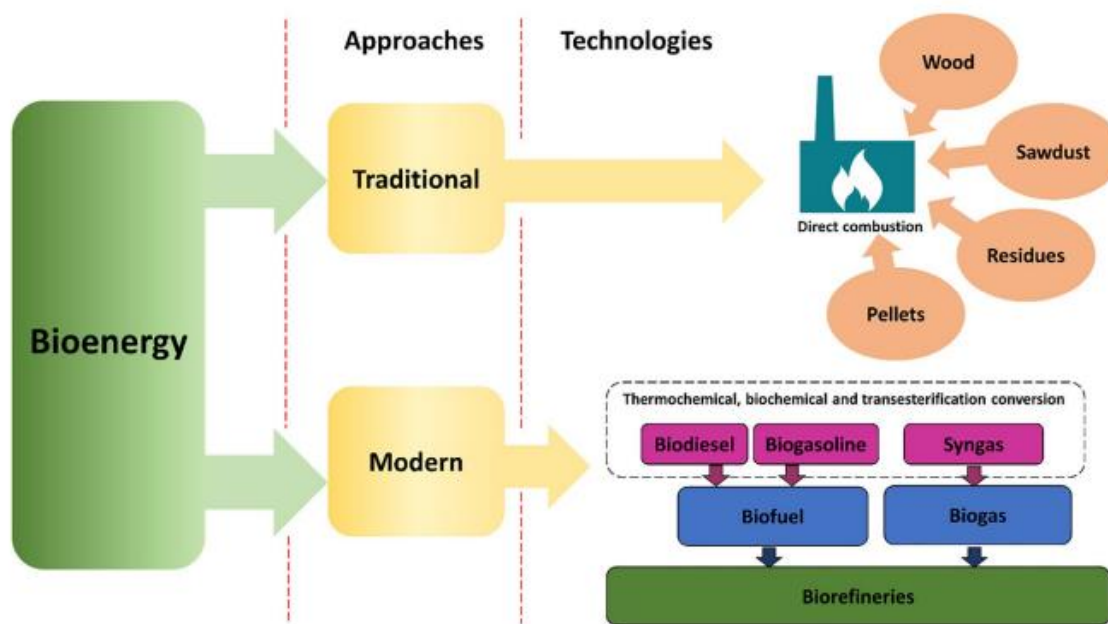

Fig. 4 Biomass Energy [13].

Components of woody biomass include lignin and glucose as their main elements. Live trees, manufacturing and forest waste, and consumer garbage are examples of this. The United States Department of Agriculture defines woody biomass as the by-products of forest management that include trees and woody plants, such as limbs, tops, needles, leaves, and other woody parts, that are cultivated in a forest, woodland, or rangeland setting [14].

III. HYBRID ENERGY SYSTEMS

Systems that generate electricity usually function either off-grid or on-grid. An on-grid connected system can use renewable resources to meet its energy needs, and the grid can supply the electricity that isn't being used. Off-grid systems are frequently found in isolated or rural areas where grid connectivity is either impossible or too expensive. Renewable electricity combined with off-grid solutions is another practical way to supply clean energy. This can boost dependability while lowering emissions and operating expenses. Numerous networked hybrid energy systems, both on and off the grid, are feasible and have been studied [15]. By ensuring power availability in the event of intermittent failures in one of the generating sources, hybrid renewable energy systems (HRESs) have

addressed the unpredictable nature of renewable energy. HRESs typically use diesel generators and/or backup batteries in addition to renewable energy as the main source. These technologies could reduce costs and optimize the size of system components, ensuring access to affordable, reliable, and sustainable energy sources while also minimizing operating expenses. Diesel generators enabled off-grid electricity, one of the earliest and most viable approaches to electrifying isolated communities.

Later, a lot of decentralized solar home systems (SHS), a small number of solar mini-grids, and mini-hydro systems appeared as a result of the main grid's erratic and slow growth, particularly in rural and remote locations. Renewable energy is currently gradually replacing or hybridizing diesel-based systems. According to a recent IRENA analysis, there are 12,000 MW of mini-grids built globally. It's unclear, though, if this simply refers to mini-grids powered by renewable energy sources or if diesel mini-grids are also included. According to estimates, the number of individuals connected to renewable mini-grids—specifically, small hydro and solar photovoltaic (PV)—rose dramatically between 2008 and 2016, rising from 0.2 million to 1.3 million in Africa and from roughly 3 million to 8.8 million in Asia. Furthermore, a technical analysis

published in 2019 by the World Bank through ESMAP estimated that at least 19,000 mini-grids, primarily powered by solar PV, hydropower, and diesel, had been constructed in 134 countries globally [16].

An economical and environmentally beneficial way to relieve the off-grid community of its reliance on fossil fuels or to steer clear of unstable and exorbitant grid connections is to rely on local renewable energy sources (RESs). To attain high RES penetration levels, electrical energy storage (EES) systems should be taken into consideration due to the changeable RESs' (like solar and wind) erratic behaviour. Because of their excellent performance, versatility, and falling costs, batteries are typically the first option for storage media. Because of its long-term storage capacity, hydrogen-based storage systems may also be required in order to fully rely on non-dispatchable RESs. Relying solely on diesel generators in off-grid locations may result in significant energy costs. Due to high operational expenses brought on by geographic remoteness (and associated transportation problems) and extremely variable fuel prices, diesel-based power generation is frequently unaffordable. However, the oversizing required to offer a dependable power supply service throughout the year can also result in high prices for energy systems that are solely reliant on local RESs. One practical way to lower the levelized cost of energy (LCOE) is through energy system hybridization [17]. By combining many energy sources, hybrid systems can provide a more reliable energy supply while mitigating the limitations and unpredictabilities of individual energy sources. For example, a hybrid system that combines solar and wind energy sources can provide electricity when there is little wind or sun radiation. The optimal design and

feasibility of hybrid energy systems (HRES) have been the subject of numerous studies. Nonetheless, a common feature among all research is the importance of energy storage components in determining the overall cost of the system. According to some studies, the cost of the storage device actually makes up a sizable amount of the cost of the HRES system. To maximize return on investment and guarantee long-term success in the HRES sector, it is imperative to invest in a high-quality, reasonably priced energy storage solution [18].

IV. CHALLENGES IN POWER QUALITY AND GRID STABILITY

The growing use of solar PVs and EVs is predicted to increase the degree of intermittency and uncertainty in the power grid on both the generation and demand sides. This could lead to distribution network overload and impact grid stability and power quality. However, solar photovoltaics and EV charging can complement each other. It can address grid stability and power quality issues that may arise from the independent integration of various devices. Furthermore, given their growing market share, PVs and EVs are likely to enter the energy sector as new players with the potential to drastically change the market. Power system stability is the capacity of a power system to resume its steady state operational condition after a disturbance. Furthermore, it is difficult to forecast how this new load will behave due to uncertainty in EV connection locations, charging duration, and period. Consequently, a high volume of EV charging could raise questions regarding the stability of the power system [19].

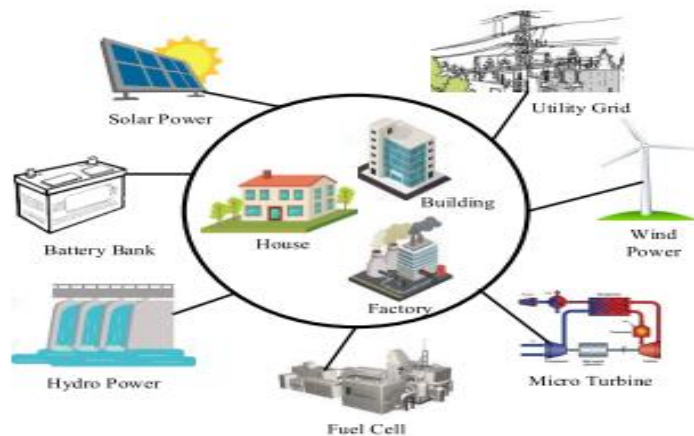

Fig.5 Structure of MG [20]

The MG is intended to increase the local community's power supply's efficiency. It is always connected at low voltages, but occasionally at medium voltages linked to certain DESs like fuel cells, microturbines, and photovoltaic, together with flexible loads and storage devices like flywheels, batteries, and energy capacitors. The structural elements of MG-RES, ESS, DG, and loads-are depicted in Fig. 5.

As a result, In recent years, the energy sector—which has historically grown slowly—has seen substantial changes. Even though they still account for a relatively small portion of the global energy mix, DGs and microgrids drastically

change traditional power networks. In general, energy systems are undergoing major change in a variety of ways. These include a change in grid infrastructure, with microgrids emerging as new alternatives to traditional distribution systems to improve integration; a shift from centralized to decentralized generation, which is primarily leaning towards renewables; and a change in consumption patterns with new consumer loads, such as energy-saving lighting systems. Even while microgrids have shown potential in recent years, they have a number of disadvantages. Their low rotational inertia is a major

disadvantage. Microgrids do not naturally generate significant inertia, in contrast to conventional synchronous generators. Microgrids that significantly integrate renewable energy sources (RESs) further highlight the potential for reduced overall system inertia. This is because considerably less inherent inertia results from the use of electronic converters rather than rotating machinery. These reduced levels of inertia can lead to a number of problems, including inefficient grid regulation, increased susceptibility to disturbances, and frequency instability. Furthermore, power systems may experience fluctuations in voltage and current due to the growing integration of DGs into utility grids. Maintaining appropriate power levels—often referred to in the literature as "Power Quality"—is one of the primary technical obstacles to DG integration into utility networks. To ensure a steady and dependable power supply, this entails making sure that the power grid's voltage and current levels stay within reasonable bounds. All power grids must have a high PQ since low PQ can lead to device failure, overuse, or malfunction altogether. Microgrids and RES-based power systems are especially vulnerable to PQ disturbances because of their special features. The intermittent nature of renewable DGs causes variations in output power. Voltage fluctuations, sags, and swells may be caused by these variations in weak microgrids, which are defined by a high R/X ratio [21].

It should be mentioned that the unparalleled drawback of intermittency or fluctuation affects both solar PV and wind power facilities. Therefore, in future power systems, operators must worry about both unpredictable demand and changeable generation. Furthermore, power electronic converters are used to link Type-3 and Type-4 wind generators as well as grid-connected solar PV to the host power system. The rotors of traditional fossil fuel-powered synchronous generators act as spinning reserves and are directly connected to the host grid. In the event of a power surplus or shortage, these spinning reserves can either absorb or provide the stored kinetic energy. This stored kinetic energy is a fundamental characteristic of conventional generators and functions as the rotors' inertia. Solar PV and Type 3 and Type 4 wind generators do not necessarily add to system inertia because they are not connected to the host power systems. The generator rotor speed change (corresponding to system frequency) might have been stopped by this system inertia. In contrast, wind-dominated power systems and solar PV do not have this feature. In contemporary integrated power networks, a high voltage ac (HVAC) or high voltage dc (HVDC) line can import electricity from a nearby generation-rich area to a load-rich location.

Consequently, a load-rich area may have very few conventional generators. A significant power imbalance and a significant departure from the nominal system frequency may result from the loss of this connection. Furthermore,

distributed generators (DGs) are being incorporated in complicated electric networks as a result of recent technology advancements and global power grid deregulation. These DGs usually function in a narrow frequency range. Consequently, these DGs may disconnect from the grid and further deviate from the nominal frequency if the system frequency drops significantly [22].

V. FAULT RIDE-THROUGH (FRT)

A key requirement of grid codes (GCs) is FRT capability, which means wind turbines (WTs), solar systems, or MGs remain connected to the grid during and after a failure within a certain limit. Because disconnecting one will generate a greater imbalance in consumption, a drop in the frequency of the system, and an increase in inrush current, a WT must trip off when the voltage drop exceeds a specific threshold. In Denmark, Ireland, and Germany, the voltage profile in GCs is determined by the fault type (symmetrical or asymmetrical). Another national grid code is specified by the voltage drop's depth. Permanent magnet synchronous generators, synchronous reluctance generators, and doubly-fed induction generators (DFIG) are examples of WT generators. DFIG is the generator most commonly used with wind energy systems due to its wide speed range. Since its converter only uses 25–30% of its power rating, power losses are negligible. Due to the high sensitivity of DFIG to grid disturbances, FRT enhancement is required. Internal control of the grid-side converter (GSC) and rotor-side converter (RSC) is recommended. A coordinated control strategy, for instance, makes use of three extra controllers (damping controllers, RSC, and GSC), a twofold degree of internal model control, the demagnetization current method, the flux vector control method, and virtual damping flux. For instance, an improved control technique on GSC makes advantage of instantaneous rotor power feedback. Robustness against parameter uncertainty is provided via the sliding mode control. With dc-link voltage, a fuzzy logic controller offers quick transient responses. An evolutionary algorithm for fuzzy logic controller tuning is proposed in this paper. Fuzzy logic is used to tune the reference adaptive internal control [23].

The Crowbar Circuit, as shown in Figure 5, is one of the most popular methods for resolving the FRT problem. Using semiconductor switches, a set of resistances is applied to the rotor-side slip ring in order to circumvent the RSPEC. This is an explanation of how it works in general: The rotor's transient current I_{rotor} in this scenario changes to I_{rotor}^f (fault current), which will dissipate in the resistance R_{crw} . At the voltage dip (such as three-phase faults), RSPEC gate signals are cut off, and the crowbar resistor shortens the rotor rings. Stated differently, point F indicates that the rotor current is then redirected to the crowbar.

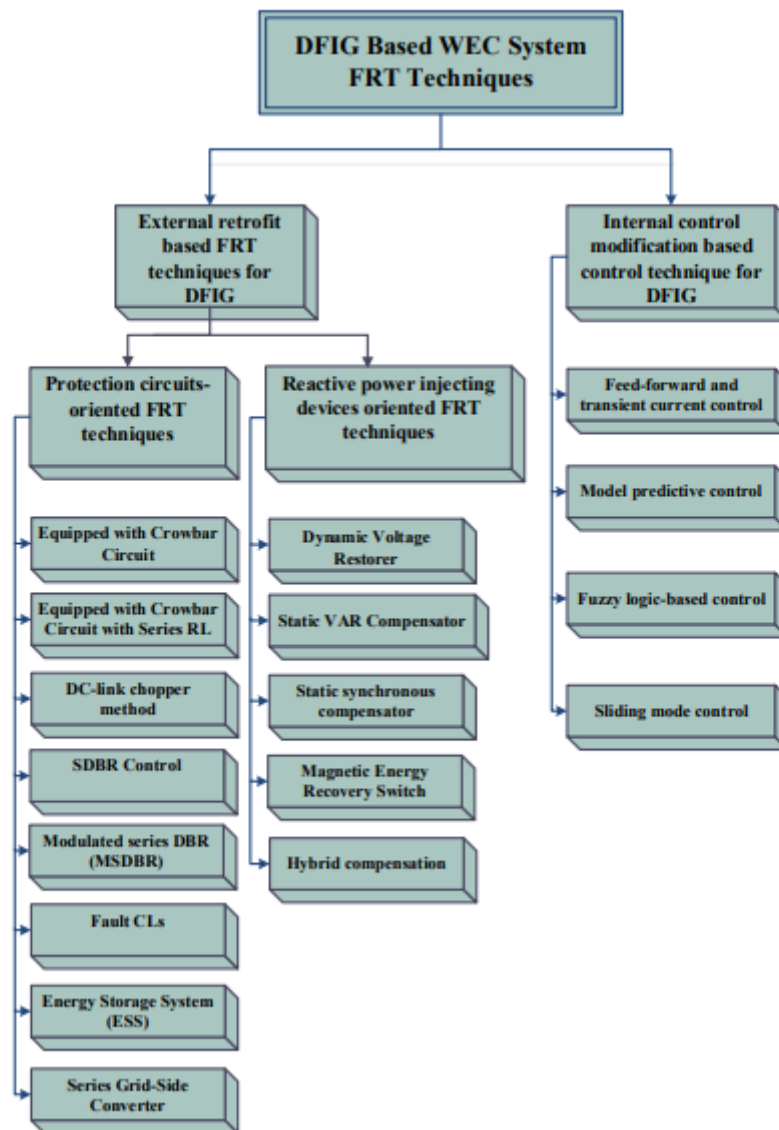

Fig.6 FRT Techniques of DFIG-based WEC systems [24].

Crowbar activation causes a progressive loss of control over the active and reactive power management capabilities of the RSPEC and wind turbine (WT). Using this method has the drawback of losing grid voltage when the DFIG-WEC system starts to function as a reactive power consumption device, like an induction motor. An enhanced model of the crowbar arrangement that can guarantee actual and reactive

power regulation will be described in the next part in order to get beyond the restrictions placed by the crowbar installation. The crowbar circuit also consists of a number of active and passive compensators, a crowbar with a DC link chopper, and a crowbar coordination concept with series dynamic resistance.

Table 1 Comparison of Key Findings, Technologies, and Limitations in Fault Ride-Through (FRT) and Power Quality

Citation	Key Findings	Technology	Limitations
25	Improved Fault Ride-Through (FRT) for wind turbines using Switched Reluctance Generator (SRG) and DVR.	Dynamic Voltage Restorer (DVR) with Fuzzy Logic Controller (FLC), MATLAB/SIMULINK simulation.	Focuses only on specific cases (balanced sag, unbalanced sag, and single line-to-ground fault).
26	Voltage compensation in grid-connected hybrid systems using EV charging stations and DVR.	EV charging stations, Flexible AC Transmission System (FACTS), DVR, MATLAB/SIMULINK simulation.	Dependency on EV availability and specific sag intensity thresholds for device operation (0.9–0.51 p.u, etc.).

27	FRT compliance techniques for Doubly Fed Induction Generator (DFIG)-based Wind Energy Conversion Systems (WECS).	Compensation devices for voltage sag/swell, grid disturbance support up to 1500 ms.	Generalized review; no specific new system or technology proposed for improved implementation.
28	Mitigating power quality issues in grid-tied PV systems using a DVR with optimized PI controller.	DVR with PI controller, Artificial Rabbits Optimization (ARO), MATLAB/SIMULINK simulation.	Focuses primarily on PV systems; may not generalize well to other RES or hybrid systems.

VI. CONCLUSION

The study highlights the critical role of hybrid energy systems and advanced technologies in overcoming the challenges posed by renewable energy integration into the grid. By employing Dynamic Voltage Restorers (DVRs), optimized control strategies, and supplementary solutions like EV charging stations, significant improvements in fault ride-through (FRT) capabilities and power quality have been achieved. The study underscores the necessity of addressing issues such as voltage sags, swells, and grid instability through effective voltage compensation and harmonic reduction techniques. Furthermore, the integration of energy storage systems enhances the resilience and reliability of hybrid configurations, addressing the intermittent nature of RESs. The findings pave the way for implementing robust solutions in both grid-connected and off-grid systems, promoting sustainable development and compliance with modern grid codes. Future research should focus on optimizing cost-effective designs and exploring emerging technologies to further enhance grid stability and efficiency in renewable-dominated systems.

Conflict of Interest: The corresponding author, on behalf of all authors, confirms that there are no conflicts of interest to disclose.

Copyright: © 2024 by Ms. Dana Narayanan and Dr. G.M. Thungesh Author(s) retain the copyright of their original work while granting publication rights to the journal.

License: This work is licensed under a Creative Commons Attribution 4.0 International License, allowing others to distribute, remix, adapt, and build upon it, even for commercial.

References

- [1] Zhang, H., Xiang, W., Lin, W., & Wen, J. (2021). Grid forming converters in renewable energy sources dominated power grid: Control strategy, stability, application, and challenges. *Journal of modern power systems and clean energy*, 9(6), 1239-1256.
- [2] Kouveliotis-Lysikatos, I., Hatziargyriou, N., Liu, Y., & Wu, F. (2020). Towards an internet-like power grid. *Journal of Modern Power Systems and Clean Energy*, 10(1), 1-11.
- [3] Ren, F., Lin, X., Wei, Z., Zhai, X., & Yang, J. (2022). A novel planning method for design and dispatch of hybrid energy systems. *Applied Energy*, 321, 119335.
- [4] Egeland-Eriksen, T., Hajizadeh, A., & Sartori, S. (2021). Hydrogen-based systems for integration of renewable energy in power systems: Achievements and perspectives. *International journal of hydrogen energy*, 46(63), 31963-31983.
- [5] Afonso, J. L., Tanta, M., Pinto, J. G. O., Monteiro, L. F., Machado, L., Sousa, T. J., & Monteiro, V. (2021). A review on power electronics technologies for power quality improvement. *Energies*, 14(24), 8585.
- [6] Zeb, K., Islam, S. U., Khan, I., Uddin, W., Ishfaq, M., Busarello, T. D. C., ... & Kim, H. J. (2022). Faults and Fault Ride Through strategies for grid-connected photovoltaic system: A comprehensive review. *Renewable and Sustainable Energy Reviews*, 158, 112125.
- [7] Wasti, A., Ray, P., Wi, S., Folch, C., Ubierna, M., & Karki, P. (2022). Climate change and the hydropower sector: A global review. *Wiley Interdisciplinary Reviews: Climate Change*, 13(2), e757.
- [8] Shahabuddin, M., Alim, M. A., Alam, T., Mofijur, M., Ahmed, S. F., & Perkins, G. (2021). A critical review on the development and challenges of concentrated solar power technologies. *Sustainable Energy Technologies and Assessments*, 47, 101434.
- [9] Patel, M. R., & Beik, O. (2021). *Wind and solar power systems: design, analysis, and operation*. CRC press.
- [10] Peng, X., Liu, Z., & Jiang, D. (2021). A review of multiphase energy conversion in wind power generation. *Renewable and Sustainable Energy Reviews*, 147, 111172.
- [11] Hanifi, S., Liu, X., Lin, Z., & Lotfian, S. (2020). A critical review of wind power forecasting methods—past, present and future. *Energies*, 13(15), 3764.
- [12] Wang, Z., Bui, Q., & Zhang, B. (2020). The relationship between biomass energy consumption and human development: Empirical evidence from BRICS countries. *Energy*, 194, 116906.
- [13] Rashidi, N. A., Chai, Y. H., & Yusup, S. (2022). Biomass energy in Malaysia: current scenario, policies, and implementation challenges. *Bioenergy research*, 15(3), 1371-1386.

- [14] Jekayinfa, S. O., Orisaleye, J. I., & Pecenka, R. (2020). An assessment of potential resources for biomass energy in Nigeria. *Resources*, 9(8), 92
- [15] Ceylan, C., & Devrim, Y. (2023). Green hydrogen based off-grid and on-grid hybrid energy systems. *International Journal of Hydrogen Energy*, 48(99), 39084-39096.
- [16] Zebra, E. I. C., van der Windt, H. J., Nhumai, G., & Faaij, A. P. (2021). A review of hybrid renewable energy systems in mini-grids for off-grid electrification in developing countries. *Renewable and Sustainable Energy Reviews*, 144, 111036.
- [17] Marocco, P., Ferrero, D., Lanzini, A., & Santarelli, M. (2022). The role of hydrogen in the optimal design of off-grid hybrid renewable energy systems. *Journal of Energy Storage*, 46, 103893.
- [18] Ennemiri, N., Berrada, A., Emrani, A., Abdelmajid, J., & El Mrabet, R. (2024). Optimization of an off-grid PV/biogas/battery hybrid energy system for electrification: A case study in a commercial platform in Morocco. *Energy Conversion and Management: X*, 21, 100508.
- [19] Tavakoli, A., Saha, S., Arif, M. T., Haque, M. E., Mendis, N., & Oo, A. M. (2020). Impacts of grid integration of solar PV and electric vehicle on grid stability, power quality and energy economics: A review. *IET Energy Systems Integration*, 2(3), 243-260.
- [20] Alkahtani, A. A., Alfalahi, S. T., Athamneh, A. A., Al-Shetwi, A. Q., Mansor, M. B., Hannan, M. A., & Agelidis, V. G. (2020). Power quality in microgrids including supraharmonics: Issues, standards, and mitigations. *IEEE access*, 8, 127104-127122.
- [21] Sepasi, S., Talichet, C., & Pramanik, A. S. (2023). Power quality in microgrids: A critical review of fundamentals, standards, and case studies. *IEEE Access*, 11, 108493-108531.
- [22] Shazon, M. N. H., & Jawad, A. (2022). Frequency control challenges and potential countermeasures in future low-inertia power systems: A review. *Energy Reports*, 8, 6191-6219.
- [23] Moheb, A. M., El-Hay, E. A., & El-Fergany, A. A. (2022). Comprehensive review on fault ride-through requirements of renewable hybrid microgrids. *Energies*, 15(18), 6785.
- [24] Ansari, A. A., & Dyanamina, G. (2022). Fault ride-through operation analysis of doubly fed induction generator-based wind energy conversion systems: a comparative review. *Energies*, 15(21), 8026.
- [25] AlGhamdi, S. A. (2023). Improvement of fault ride-through capability of grid connected wind turbine based on a switched reluctance generator using a dynamic voltage restorer. *Sustainability*, 15(14), 11061.
- [26] Uthra, R., & Suchitra, D. (2021). Fault ride through in grid integrated hybrid system using facts device and electric vehicle charging station. *Energies*, 14(13), 3828.
- [27] Shuaibu, M., Abubakar, A. S., & Shehu, A. F. (2021). Techniques for ensuring fault ride-through capability of grid connected dfig-based wind turbine systems: a review. *Nigerian Journal of Technological Development*, 18(1), 39-46.
- [28] Ibrahim, N. F., Alkuhayli, A., Beroual, A., Khaled, U., & Mahmoud, M. M. (2023). Enhancing the functionality of a grid-connected photovoltaic system in a distant Egyptian region using an optimized dynamic voltage restorer: Application of artificial rabbits optimization. *Sensors*, 23(16), 7146.