

Review on Power Distribution Techniques in System Comprising of BESS

Ajay Kumar Gupta

M.Tech Scholar

IES College of Technology
Bhopal, M. P, India
ajaykumargpt587@gmail.com

Jyoti Bansal

Assistant Professor

IES College of Technology
Bhopal, M.P, India

Abstract – With regard to electrical energy sector, budgetary factors, power must be utilized as soon as possible once it is generated. Since storing large amounts of electrical energy is prohibitively expensive. Consequently, as energy storage substance have become mostly accessible, evenly distributed production is becoming more workable, especially with the Smart Grid concept. Distributed ESS (Energy Storage Systems) are gaining popularity. There is a diverse category of ESS namely, battery, thermal, mechanical, hydrogen and so on. But this paper investigates about the techniques used in Battery energy systems by several researchers to stabilize energy output and usage, these systems supplement variable renewable sources such as wind, tidal, and solar power.

Keywords: ESS, BESS, Micro-grids, Distribution Generators, Types of BESS.

I. INTRODUCTION

BESS (Distributed Energy Storage Systems) are gaining popularity. Throughout the ESS constructional procedure, three criteria must be considered in broad sense. Case studies include the size distribution (kW to MW), main objective discharging period (seconds to hours), and functioning cycles (cycles per year). ESS deployments can be classified into two groups: 1) power implementations and 2) energy usage. Energy uses necessitate a much longer abilities and an elevated power rating (kWh), whereas power implementations necessitate a massive power potency with a much lower discharge timeframe (higher kW).

The most long-term framework to de-carbonization the power sector is distributed generation involving sustainable energy. A micro-grid (MG) is a topology for DG integration that is defined as a low voltage (LV) mechanism including a cluster formation of distributed generators (DGs) and loads connected to it. The MG can operate whether in a grid linked or a stand-alone method. Wind turbines (WT), photovoltaic (PV) generators, and other infrequent DGs will cause a supply of power and demand incompatibility in MG. As a result, frequency is critical smooth operation in Micro grids.

In grid linked phase, MG exchanges generated electricity with the upstream grid to preserve power supply and

requirement stability; in autonomous mode, the frequency task is much greater. Something like an energy storage system (ESS) is seen as a feasible solution to this challenge. The ESS with rapid dynamic reaction can maintain power balance by exchanging instant power including MG.

II. LITERATURE REVIEW

One-of-a-kind CMC dependent energy storage system with an auxiliary power loop for power exchange across H-bridges is suggested in this study by (Jiang et al., 2017). A series LC branch is added to CMC, and dual-frequency phase-shifted carrier PWM technique is used to incorporate the auxiliary power loop (DF-PSC PWM). The voltages at fundamental and auxiliary frequencies are independent of each other as per mathematical assumptions in DF-PSC PWM. Controlling phase fluctuations among auxiliary frequency voltages allowed power to be moved from one H-bridge to the other. In a CMC-based battery energy storage system, the proposed power exchange technique could be used for SOC-balancing. A technique for day-ahead preparing and actual strategic planning of a photovoltaic (PV) plant with a battery energy storage system that is interconnected (BESS). The best daily energy distribution profile based on an assumption of PV production is identified by day-ahead algorithm. The study given by (Conte et al., 2018) addresses the DAP and RTOC dilemmas for an incorporated PV-BESS system. Two very different proposed techniques employed chance-constrained processes that had been established to combine a stochastic model of long-term and short-term PV power forecasts in the issue. To model a hybrid building complex with a BESS connected to the distribution system this paper was presented by (Noshahr et al., 2020). The consumption demand for residential structures is investigated over a one week period. The Matlab/Simulink software environment was used to design and simulate under investigative process. Over the course of a week, the simulated results revealed that 388kWh of the PV system's output produced of 725kWh is used to power residential loads, while the leftover 337kWh is stored in the BESS. The memorandum is made up of a collection of research projects that include energy storage technologies and a power electronics network. In medium and high voltage power networks, battery energy storage with multiple-layer converter topologies is incredibly appealing; however, SOC balancing stays a big challenge. A DC-link voltage efficient algorithm for SOC equilibrium control of a

BESS has been presented by (Sirisukprasert, 2014) based on a 7-Level CMC. The primary goal of the framework of the research is to show the advantages of coming into direct contact to a battery with a STATCOM, which is alluded to as a Battery Energy Storage System (BESS). Modeling of STATCOM, BESS, and controller layout for enhancing and attempting to control the performance of the system with respect to voltages, as well as damping of oscillations to improve durability, are also mentioned briefly by (Singh & Hussain, 2010). In order to achieve maximum BESS revenues, this work by (Hu et al., 2010) suggests an effective methodology for battery energy storage systems in relation to the original electricity prices. The study looks into two types of BESS that use PSB and VRB battery technology. According to the computation, the recommended ideal operating method is an excellent way to boost BESS profitability. Despite the fact that the VRB battery's annual revenue is higher than the PSB battery's, the PSB battery's repayment duration will be shorter than the VRB battery's. The research work done by (Nempu et al., 2020) concentrates on a power smoothing framework for a WECS that uses a BESS-based basic control scheme. The WECS is regulated using the MPPT method. The BESS is employed to offer or absorb power even if there are temporary inconsistencies in power. The MPPT algorithm assists in attaining maximum power from the turbine at all times. The study relied on sporadic wind information. The system's DC bus is equipped with a BESS with a voltage-current controller, and it is revealed that the BESS efficaciously smooths the output power of the WECS. This study proposes a strategy depending on a loss sensitivity index for determining the BESS's suitable area in the PDS (power distribution system). Even though the BESS is in the ideal possible destination, its dimension has a great impact on the ability of the PDS. The suggested technique was validated using data from the Ontario electrical distribution utility grid. A controller depending on PSO (particle swarm optimization) is addressed to determine the appropriate rating of the BESS to be installed in the given substation.

A coordinated voltage control strategy for multi-microgrid distribution networks is presented in this study by (Sun & Zhang, 2018). The optimal functioning of the voltage and power interaction at point of common coupling will be achieved through iterative relationships of the voltage and power transfer. The coordinated control of OLTC, Sh.Cs, DGs, and microgrids greatly enhances distribution system voltage profiles since guaranteeing microgrid economic models. The results of a 33-bus distribution network with multi-microgrids show the effectiveness of the recommendation of control technique. This study looks into the possibility of integrating a BESS locally in problematic distribution grids. A BESS could reduce both overvoltage and overload concerns by combining voltage control and peak shaving techniques as shown in figure below. Voltage control using active and reactive power may allow extra PV to be deployed while grid improvements are postponed. The study given by (Tant et al., 2013) findings show trade-offs in three areas: voltage control, peak apparent power

minimization, and annual cost. The proposed methodology is intended to assist in the BESS installation decision-making process. The method determines the cost of achieving a specific level of technical performance. In a cost estimate, the value of this technology support should be considered.

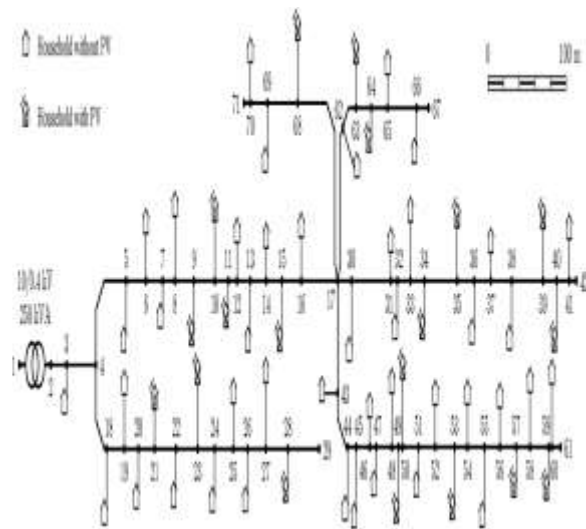

Figure 1 Schematic diagram of the semiurban feeder used in the scenario given by (Tant et al., 2013).

The effectiveness of the aggregated BESS engaging in frequency control is examined in this research done by (Chen et al., 2016). Frequency regulation performance testing and size analyses are examples of research. Both computational simulations and hardware implementations are carried out. As per the NERC performance indices, the proposed BESS penetration rate in the power system is studied using an iterative technique.

III. ENERGY STORAGE SYSTEMS

There is now a surge in curiosity through distributed generation (DG) in current history. This is largely due to the excellent properties of DGs, which include diminished electrical energy wastages in the distribution structures, lesser voltage fluctuations, enhanced reliability, boosted power quality, reduced expenses, and, ultimately, happier customers. Despite all of the advantages of DG in power systems, trying to integrate these technological breakthroughs into nationwide energy systems raises a several quantity of issues, including changing the defensive configuration, power reliability, and the islanding circumstance.

Natural energy resources, like wind and solar power-plants, and finite resources, such as fossil fuels, are frequently used in distributed generators (conventional methods). Mostly natural energy resources, such as wind farms and photovoltaic (PV) equipment, reveal two major issues when used as DGs: output power relocations and unpredictability. Indeed, the usage of DGs in a power network is complicated by these primary elements. The employment of an energy

storage system (ESS) is one of the most acceptable methods in this zone. This new genre aids the developer in power system control optimization.

IV. TYPES OF ENERGY STORAGE SYSTEMS

There are many distinctive types of energy storage solutions available for use in the energy sector, and many others are on the way as innovation is now a critical aspect in the energy market around the world and continues to years ahead. As the company's demand for energy storage grows, so will the range of options available, as needs are becoming more concise and advances based on cutting-edge processes and equipment are developed. Even though the requirement for storing energy is really not latest – people have been looking for ways to store energy produced during peak periods for subsequent use to avoid energy demand-supply incompatibilities – the business is continuously widening.

Including the rise of variable wind & solar energy, decentralization of the power grid, and the need for network resilience, frameworks appear to be becoming more diverse and geographically diverse. Though since wind and solar creation are dependent on local climatic changes, short-term variants are possible, so yielding periods might not even coincide with demand periods. As a result, a wide range of interventions is needed. Energy storage systems (ESS) range from quick fixes for relatively close and daily systems administration to longer-term solutions for unpredictable week-to-week changes and more predictable seasonal market fluctuations. Examples of key use situations include power quality assurance and load balancing, as well as backup generators for failure monitoring.

The diverse categories of energy storage can be assembled into five broad technology classes: Batteries, Thermal, Mechanical, Pumped hydro, Hydrogen. Batteries are an electrical and chemical unique trait inside one or more cells including a positive terminal widely recognized as a cathode and a negative terminal recognized as an anode. They are the oldest known, most widely known, and widely accessible method of storage. A wide range of compositions are used in batteries. The most well-known and widespread applied batteries in portable electronic devices and automobiles are lithium-ion & lead acid batteries. Thermal storage refers to the absorption and emission of temperature fluctuations in solids, fluids, and gases, and also potential phase variations in the storing medium, including from gas to fluid state, solid state to liquid state, and vice versa.

Mechanical storage methodologies, that also store energy using the kinetic forces of spinning or gravitational forces, are the most fundamental basis. Practicality, on the other hand, requires the usage of cutting-edge innovation in today's modern application areas. Energy storage employing flywheels and air compressor equipment are the most common options, while gravitational energy is a novel approach with a variety of options. Pumped hydro methods, which rely on massive water impoundments, have been developed and deployed for most of the last century, and have become the most popular form of power distribution storage around the known universe.

V. BATTERY ENERGY STORAGE SYSTEMS

The Battery Energy Storage System (BESS) is a system that stores electric charge in specially designed batteries. The central assumption is that some energy can be saved and used at a point later. Battery advancements have resulted from a vast field of theory, making the concept of a Battery Energy Storage System a pragmatic truth. A subtype of Energy Storage Systems is BESSs (Battery Energy Storage Systems) (ESSs). The term "energy storage system" refers to a system that can store energy using thermal, electro-mechanical, or electro-chemical techniques. BESS is superior to all other storage technologies in that it is small in size and has no territorial restrictions on where it could be placed. Due to water and siting limitations, as well as transmission constraints, alternate solution of storage methods such as pumped hydro storage (PHS) and compressed air energy storage (CAES) are now only relevant for a limited timeframe. As a necessary consequence, BESS depending on Lithium Ion techniques offer excellent energy and power densities, making them ideal for use in distribution transformers. At the distribution transformer arrangement, the BESS can be placed in the existing space.

The combination of electrical and chemical components is used to operate BESS mostly. All Energy Storage Systems, in actuality, collect energy and store it for later use. These technologies include pumped hydro, air compressor storage, mechanically flywheels, and now BESSs.

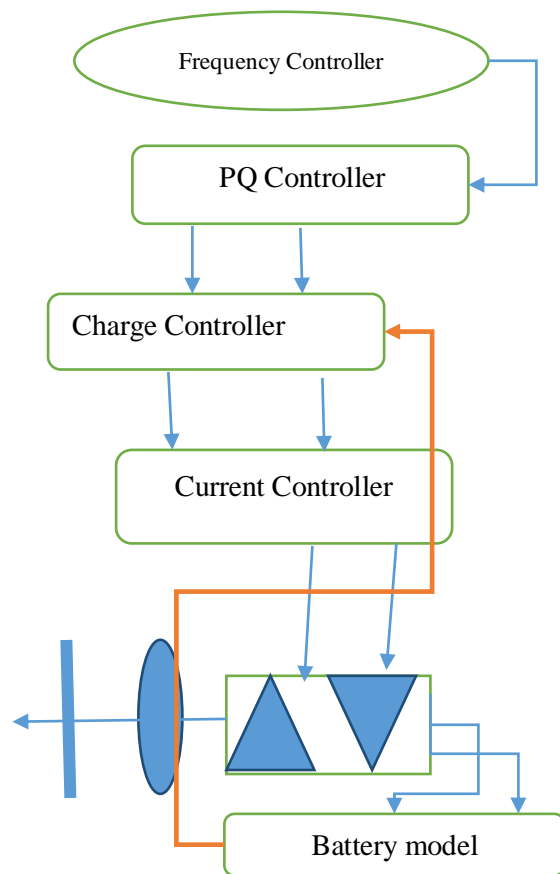

Figure 2 Battery Energy Storage Systems

VI. MICRO-GRIDS

A microgrid is a regional energy grid with control capabilities that allows it to operate independently of the main grid. The grid is basically used to connect homes, enterprises, as well as multiple frameworks to centralised power sources, enabling us to use equipment, air conditioners, and other electronic devices. As the grid is so interconnected, when a component of it needs to be revived, it affects everyone. A microgrid can help in this situation. A microgrid typically operates while connected to the grid, but in times of crisis, such as hurricanes or power outages, or for other reasons, it may detach and operate independently using local electricity production.

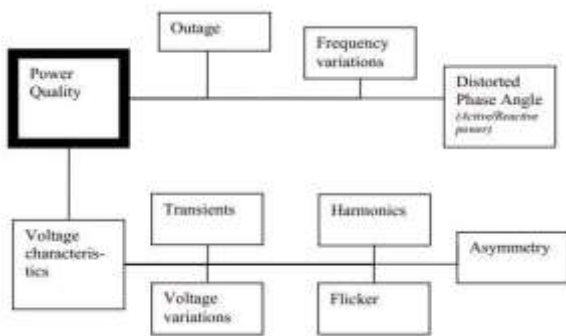

Figure 3 Categorization of Power Quality

Microgrids are a fastest - growing sector of the energy industry, indicating a shift away from distant central station power plants and toward more localised, distributed generation, especially in cities, towns, and campuses. Microgrids are resilient because they can operate independently of the main grid, and their ability to perform flexible, parallel operations allows for the provision of capabilities that make the grid more viable. A microgrid can continue to serve many loads while the grid is down, as well as serve its surrounding neighbourhood by creating a platform to endorse critical services ranging from sponsoring first responders and governmental functions to supplying key services and emergency housing, by "islanding" from the grid in times of distress. Microgrids provide efficient, low-cost renewable energy while also enhancing local adaptability and the overall operation and sustainability of the electric grid. They provide an energy resource with previously unheard-of levels of dynamic reactivity.

VII. CONCLUSION

The techniques used by several researchers in Battery energy systems to stabilize energy output and usage were investigated in this paper. These systems supplement variable renewable sources such as wind, tidal, and solar power. As a result, as energy storage materials become more widely available, evenly distributed production becomes more feasible, particularly with the Smart Grid concept. Energy Storage Systems (ESS) that are distributed are becoming

more popular. There are many types of ESS, including battery, thermal, mechanical, hydrogen, and so on.

REFERENCES

- 1) Jiang, W., Huang, L., Zhang, L., Zhao, H., Wang, L., & Chen, W. (2017). Control of Active Power Exchange with Auxiliary Power Loop in a Single-Phase Cascaded Multilevel Converter-Based Energy Storage System. *IEEE Transactions on Power Electronics*, 32(2), 1518–1532. <https://doi.org/10.1109/TPEL.2016.2543751>
- 2) Conte, F., Massucco, S., Saviozzi, M., & Silvestro, F. (2018). A Stochastic Optimization Method for Planning and Real-Time Control of Integrated PV-Storage Systems: Design and Experimental Validation. *IEEE Transactions on Sustainable Energy*, 9(3), 1188–1197. <https://doi.org/10.1109/TSTE.2017.2775339>
- 3) Noshahr, J. B., Mohamadi, B., Kermani, M., & Kermani, M. (2020). Operational Planning of Inverter Control in a grid connected Microgrid with hybrid PV and BESS. *Proceedings - 2020 IEEE International Conference on Environment and Electrical Engineering and 2020 IEEE Industrial and Commercial Power Systems Europe, IEEEIC / I and CPS Europe 2020*. <https://doi.org/10.1109/IEEEIC/ICPSEurope49358.2020.9160692>
- 4) Sirisukprasert, S. (2014). Power electronics-based energy storages: A key component for Smart Grid technology. *2014 International Electrical Engineering Congress, IECON 2014*. <https://doi.org/10.1109/IECON.2014.6925979>
- 5) Singh, B., & Hussain, Z. (2010). Application of Battery Energy Storage System (BESS) in voltage control and damping of power oscillations. *2010 5th International Conference on Industrial and Information Systems, ICIIS 2010*, 514–519. <https://doi.org/10.1109/ICIINFS.2010.5578649>
- 6) Hu, W., Chen, Z., & Bak-Jensen, B. (2010). Optimal operation strategy of battery energy storage system to real-time electricity price in Denmark. *IEEE PES General Meeting, PES 2010*, 1–7. <https://doi.org/10.1109/PES.2010.5590194>
- 7) Nempu, P. B., Jayalakshmi, N. S., Kudva, G., & Topaloglu, M. E. (2020). Mitigation of Power Fluctuations of a Grid-Tied Wind Energy System Using Battery Storage System. *Proceedings of CONECCCT 2020 - 6th IEEE International Conference on Electronics, Computing and Communication Technologies*, 2(1), 2–6. <https://doi.org/10.1109/CONECCCT50063.2020.9198682>
- 8) Karanki, S. B., & Xu, D. (2017). Optimal capacity and placement of battery energy storage systems for

- integrating renewable energy sources in distribution system. 2016 National Power Systems Conference, NPSC 2016. <https://doi.org/10.1109/NPSC.2016.7858983>
- 9) Sun, X., & Zhang, W. (2018). Coordinated optimal voltage control strategy in distribution networks with multi-microgrids. Asia-Pacific Power and Energy Engineering Conference, APPEEC, 2018-October, 88–93. <https://doi.org/10.1109/APPEEC.2018.8566429>
- 10) Tant, J., Geth, F., Six, D., Tant, P., & Driesen, J. (2013). Multiobjective battery storage to improve PV integration in residential distribution grids. *IEEE Transactions on Sustainable Energy*, 4(1), 182–191. <https://doi.org/10.1109/TSTE.2012.2211387>
- 11) Chen, S., Zhang, T., Gooi, H. B., Masiello, R. D., & Katzenstein, W. (2016). Penetration rate and effectiveness studies of aggregated BESS for frequency regulation. *IEEE Transactions on Smart Grid*, 7(1), 167–177. <https://doi.org/10.1109/TSG.2015.2426017>
- 12) Alhejaj, S. M., & Gonzalez-Longatt, F. M. (2016). Investigation on grid-scale BESS providing inertial response support. *2016 IEEE International Conference on Power System Technology, POWERCON 2016*. <https://doi.org/10.1109/POWERCON.2016.7754049>
- 13) Mehrjerdi, H. (2019). Simultaneous load leveling and voltage profile improvement in distribution networks by optimal battery storage planning. *Energy*, 181, 916–926. <https://doi.org/10.1016/j.energy.2019.06.021>
- 14) Gbadega Peter, A., & Saha, A. K. (2020). Adaptive model-based receding horizon control of interconnected renewable-based power micro-grids for effective control and optimal power exchanges. *2020 International SAUPEC/RobMech/PRASA Conference, SAUPEC/RobMech/PRASA 2020*. <https://doi.org/10.1109/SAUPEC/RobMech/PRASA48453.2020.9041136>
- 15) Xie, C., Wang, D., Lai, C. S., Wu, R., Huang, J., & Lai, L. L. (2020). Optimal Sizing of Battery Energy Storage System in Smart Microgrid with Air-conditioning Resources. *2020 IEEE International Smart Cities Conference, ISC2 2020*. <https://doi.org/10.1109/ISC251055.2020.9239044>