

Review on the Techniques Used for Enhancing Performance of UPQC Structures

Sikandra Kumar Mandal

M. Tech Scholar

Rabindranth Tagore University

Bhopal, M.P., India

kumar.sikandra29@gmail.com

Nishi Singh

Professor

Rabindranth Tagore University

Bhopal, M.P., India

nishi.20.singh@gmail.com

Abstract: In a power transmitting network, a Unified Power Quality Conditioner is used to operate both shunt—connected and series-connected compensation simultaneously. Destabilize, disturbance, and sometimes even dc elements can all be found in a power distribution network. As a result, a UPQC (Unified Power Quality Conditioner) outperforms a Unified Power Flow Conditioner (UPFC) in many of these areas to offer shunt-connected or series-connected compensation. The main objective of this paper is to provide the overview, different designs given by many researchers to improve the performance of the UPQC.

Keywords: UPQC, UPFC, Series-connected, Shunt- connected.

I. INTRODUCTION

The contentious issue in the industrial sector which relies on Power is Quality of Power (Power Quality) because it affects both electrical-energy producers and consumers, as well as the grid operator. Due to extraordinary renewable absorption especially in low as well as middle system, and several unorthodox customers including electrical automobile chargers, cloud services, and massive commercial consumers communicating the power distribution area, PQ is becoming more relevant in modern years. For the power engineer of the electricity power system, power-quality disruptions are a major issue. Power-quality (P-Q) disturbances takes place due to loading fluctuations conditions and also other happenings like transients, harmonic-components, shrink, deform, and distractions, that also influence the power demand respondents to obtain. The power network's consistency and continuity will suffer as a result.

The UPQC can accommodate for voltage-based power quality challenges, since a power-transmission network consists of DC elements, disruptions, and mismatching in both voltage-levels and current-levels since executing shunt-connected and series-connected compensation. The Unified Power Quality Conditioner is used in distribution network to operate both shunt and series compensation, enabling current

in shunt compensation and voltage in series compensation to be suppressed at the same period.

The UPQC has the capability to enhance system reliability on electrical-power allocation systems and commercial electrical-networks at the construction site. As a result, the Unified Power Quality Conditioner should be one of the greatest tool to improve the efficacy for large storage loads that are affected by power supply voltage fluttering or disparity. The Unified Power Quality Conditioner is separated into two sections: a UPQC for a flicker or imbalance delicate load implemented by electricity customers on their venue, and a Unified power quality for a flicker or disparity responsive load implemented by electric utilities on their venue.

The active sequential power filtration system in Unified Power Quality Conditioner causes an emerging passive shunt filtration system to soak up the harmonic currents obtained by fluctuating load by blinking or unbalancing the voltage source with the voltage throughout the load. The suppressing of voltage source flicker is, moreover, supplemented by a lower frequencies variation of the active series filter's real power feed or outcome. The sequential active shunt filtration system is an amalgamation of a sequential active filter and an active shunt filter, as the title indicates.

The Unified Power Quality Conditioner Techniques for Control

The three levels of the UPQC control scheme are as follows:

- 1) Indications of Voltage (V) and current (I) are noted.
- 2) Compensation commands are acquired that correspond to the voltage (V) and current (I) levels.
- 3) Pulse width modulation, hysteresis, or fuzzy logic based techniques are used to generate control commands for the Unified Power Quality Conditioner strong phase switching devices.

Unified Power Quality Conditioner involves two IGBT-based VSCs, one shunt and one series, all connected by a standard DC transfer. Series-connected and shunt-connected power converters, DC capacitors, latent low-pass and high-pass channels, and series and shunt transformers are all essential components of a UPQC.

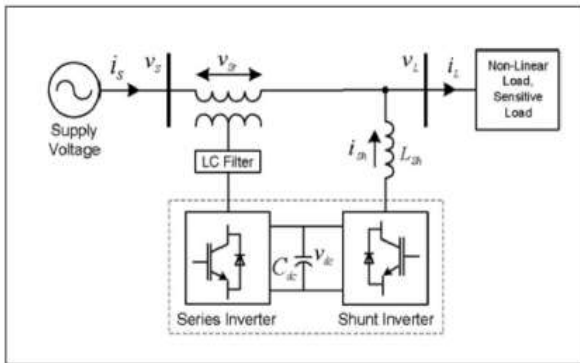

Figure 1 Block Diagram of UPQC

Series Converter

A voltage converter is a device that is linked-up in series with an AC power line and acts as a voltage source to reduce voltage flexing. It's used to prevent supply voltage flashing as well as lopsided features throughout the heap, as well as powering the detour subsidiary to keep the non-direct load's current noises. Sine wave PWM is commonly used to modify the sequential converter's output voltage. The gate pulses needed for the converter are determined by comparison a signal's ground voltage reference with a triangle shaped high frequency.

Shunt Converter

Shunt Converter is a voltage-converter depending on a common AC line that is used as a force supplier to suppress current disfigurement, compensate for the heap's interactive current, and increase the force aspect. It also implements the transient circuit's voltage recommendation, resulting in a significant reduction in the DC capacitor's force. By managing the situation of the strong state switching devices, the shunt converter's produce current is modified thru an exceptional hysteresis controller, ensuring that the output current describes the benchmark indication and remains within a predetermined hysteresis controller.

A UPQC is an entrepreneurship extension of the Unified Power Flow Conditioner concept. The Active Power Filter and Shunt-Active Power Filter sequences dynamic power channels wired in series on the DC side and providing a typical DC capacitor, are combined in UPQC. Up-stream disruptions such as voltage loss, blinking, asymmetrical voltage, and harmonic components are attenuated by the series element's UPQC. Enter limits to maintain the load limitation manageable and distortion-free at the required level.

II. LITERATURE REVIEW

A new control strategy which depends on SRF, is utilized in the UPQC to compensate power factor, as well as harmonics-voltage and harmonics-current, when the main supply voltage is not preferable and the current at the load is not in balancing condition. Depending on the SRF concept, the proposed methodology for the series-connected Active Power Filter utilizes only loads and main voltage supply dimensions. The simulated outcome demonstrated that the above stated control scheme excludes the effect of deformations and poorly balancing of load-current on the power line while being under unequal and fluctuated load-current situations, resulting in a power factor of unity [1]. The implementation of the Discrete wavelet transforms and MRA for retrieving the foundational element of load-current and voltage-source of the power network is expanded in this publication to acquire current (I) and voltage (V) references for trying to compensate for the UPQC project's deformation of these oscillations. MRA is used to retrieve the foundational element of source current and voltage, and afterwards the LS methodology is used to retrieve its amplitude, phase-angle, as well as frequency. It is showed that the suggested methodology is responsible of efficiently and precisely predicting the amplitude and phase-angle of a disrupted signal [2]. Another strategy of UPQC in which series connected and shunt connected active power filters are embedded with UPQC to compensate not only negative sequence current sequence, responsive power as well as regulate unbalance voltage levels which appears at the PCC. On practically experimenting it is declared that this scheme is applicable, effective in nature and also provide satisfied compensations [3]. For simultaneous voltage (V) and current (I) compensation in adjoined distribution lines a novel configured structure is presented in this document. Multiple converter UPQC is the newest setup (MC-UPQC). In dual feeding systems, the configuration is particularly adept safeguarding significant and crucial loads which are in against of distortions, sags/swells, and interference on comparing with a conventional UPQC. By incorporating further sequences of VSCs, the concept could philosophically be prolonged to multi-bus or multiple feeder frameworks [4]. Throughout voltage sag and swell circumstances on the structure, an analysis with the concepts of UPQC was performed. The Active Pass Filters in series when injects in phase-voltage throughout voltage sags and out of phase-voltage throughout voltage swells, ensuring that the voltage at the connected load remains unchanged. Throughout voltage sag and swell conditions, the Active Power Filter shunt assists Active Power Filter in series by keeping the dc link voltage at a consistent rate, allowing series APF to efficaciously provide or accumulate active-power [5]. A unified load and source compensation technique that use the Unified Power Quality Conditioner (UPQC) by author in this

research work. The UPQC's performance was assessed using a typical industrial load and workable specifications provided by a contaminated distribution system. The system's performance was assessed for harmonic current, voltage-harmonics, voltage sagging and swelling [6]. Traditional methodologies, such as root-locus, provide a convenient and straightforward option for designing and selecting system variables. This article illustrates how a UPQC using single-phase power batteries can be monitored using this method. A systematically arranged working steps for identifying the factors that can be expanded up to the maximum power networks is also demonstrated. The transient and steady state inaccuracy effectiveness of linear controllers is adequate, despite the fluctuating behavior of the geometry. The working principle is confirmed by simulations and experiments [7]. A new recommendation for the placing, incorporation, and regulation of UPQC (Unified Power Quality Conditioner) in Distributed generation depending grid connected or autonomous microgrid or microgeneration structures is introduced by researchers in their research work. The PCC houses the Distributed generation converters (including storage) as well as the shunt component of Unified Power Quality Conditioner (APF-sh). The series component (APFse) is constructed by connecting in series with the grid and attached prior to the PCC. The storage medium can still be linked to the DC link. As alternative control scheme, the UPQC includes an exquisite islanding sensing and rapprochement method [8]. By establishing the generalized VA loading formulae of Unified Power Quality Conditioner systems, the concepts of fluctuation with in rating of the UPQC network with fluctuation in angle of dislocation among source and load voltages has now been investigated in this work. Conceptual study is done on an algorithm which was proposed to determine the UPQC system's least possible VA rating, as well as the effective angle of dislocation, series connected inverter, shunt connected inverter, and series connected transformer ratings [9]. The implementation of a Unified Power Quality Conditioner (UPQC) in a DG system is addressed in this section. Even though ultimate focus of UPQC is to reduce voltage-level of grid and load-current interruptions while also compensating for real and reactive power and also power of harmonics, it also has other functions including voltage interference compensation and active power exchange to the load & grid. The benefits and drawbacks of various connecting strategies are also discussed [10]. This document developed an improved synchronous-reference framework (SRF)-relying on control strategies for Shunt-active active-filter and an automatic Power quality philosophy relying on controlling methods for series-active filter to compensate power-quality (P-Q) issues via thyristor. The exceptional UPQC equipment provided in this research

compensates for both active-current deformation compensation and power-aspect correcting, as well as reducing supply-voltage fluctuation at the side of load [11]. The Accessible UPQC is proposed as a way of enhancing power-quality in Distribution systems in this article by the authors. Throughout the Smart Domo Grid research work, an Accessible UPQC including solitary series-unit and five shunt-units was developed, modelled, and assembled. The focus of the research work is on an LV grid including an elevated PV penetration rate. The Accessible UPQC system was designed using the P-Q assessment and load-allocation of this sector as inputs. There must have been some modelling of the dual-elements as well as information from the presentation [12]. Because of network compensating specifications, the optimised VA ratings of the converters inside the Unified Ppwer Quality Conditioner are researched systematically by the researchers here. The phase angle control (PAC) technique is explored and demonstrated, with the ability to change the web - based VA loading by modifying the respective angle of dislocation. A dual stage method is used to improve the ratings of the shunt - connected converters and series-connected converters in getting the highest utilization rates of the power converters in the UPQC, depending on the parameter of PAC technique. Furthermore, the associated control technique is used to mitigate the presented UPQC web - based VA factor loading for the various compensating operational processes [13]. This article presents a novel Unified Power Quality Conditioner functionality, referred to as Phase Angle Conditioner of UPQC, where both the shunt-connected active pass filters and series-connected active power filters APFs share the load-reactive power requirements. This article contains the entire numerical simulations. Comprehensive models and experimental investigations are used to evaluate the proposed method [14]. This paper presents a comprehensive survey of the UPQC for improving electric power-quality at the distribution system. Latest surges in concern in renewable energy production, particularly massive scale photo-voltaic (pv) and wind systems depending on front-end inverters, are imposing unique demands in integrating these supplies into emerging transmitting systems whereas maintaining appropriate power-quality benchmarks. In this case, UPQC could be used to compensate for both voltage and current-related power-quality issues at the same time [15].

III. CONCLUSION

In order to improve the compensation of negative reactive power, distortions as well as unbalanced voltage levels, many researchers have putted their efforts in developing numerous techniques which were discussed in this paper. A Unified Power Quality Conditioner is used in a power transmission network to operate both shunt-connected and series-connected

compensation at the same time. In a power distribution network, destabilise, disturbance, and even dc elements can all be found. As a consequence, in several of these areas, a UPQC (Unified Power Quality Conditioner) outperforms a UPFC (Unified Power Flow Conditioner) to provide shunt-connected or series-connected compensation. The main goal of this paper was to have an overview of the various designs proposed by many researchers to improve the UPQC's performance.

REFERENCES

- [1] UPQC under unbalanced and distorted load conditions. *IEEE Transactions on Industrial Electronics*, 58(9), 3967–3975. <https://doi.org/10.1109/TIE.2010.2100330>
- [2] Forghani, M., & Afsharnia, S. (2007). Online wavelet transform-based control strategy for UPQC control system. *IEEE Transactions on Power Delivery*, 22(1), 481–491. <https://doi.org/10.1109/TPWRD.2006.883026>
- [3] Jianjun, G., Dianguo, X., Hankui, L., & Maozhong, G. (2002). *Unified Power Quality Conditioner (UPQC): the Principle, Control and Application*. 80–85.
- [4] Mohammadi, H. R., Varjani, A. Y., & Mokhtari, H. (2009). Multiconverter unified power-quality conditioning system: MC-UPQC. *IEEE Transactions on Power Delivery*, 24(3), 1679–1686. <https://doi.org/10.1109/TPWRD.2009.201682>
- [5] Khadkikar, V., Chandra, A., Barry, A. O., & Nguyen, T. D. (2006). Conceptual study of unified power quality conditioner (UPQC). *IEEE International Symposium on Industrial Electronics*, 2, 1088–1093. <https://doi.org/10.1109/ISIE.2006.295788>
- [6] Khadkikar, V., Chandra, A., Barry, A. O., & Nguyen, T. D. (2006). Application of UPQC to protect a sensitive load on a polluted distribution network. *2006 IEEE Power Engineering Society General Meeting, PES*, 6–11. <https://doi.org/10.1109/pes.2006.1709522>
- [7] Muñoz, J. A., Member, S., Espinoza, J. R., Baier, C. R., Morán, L. A., Espinosa, E. E., Melín, P. E., Member, S., Sbárbaro, D. G., & Member, S. (2012). *Design of a Discrete-Time Linear Control Strategy for a Multicell UPQC*. 59(10), 3797–3807.
- [8] Khadem, S. K., Basu, M., & Conlon, M. F. (2015). Intelligent islanding and seamless reconnection technique for microgrid with UPQC. *IEEE Journal of Emerging and Selected Topics in Power Electronics*, 3(2), 483–492. <https://doi.org/10.1109/JESTPE.2014.2326983>
- [9] Ambati, B. B., & Khadkikar, V. (2014). Optimal sizing of UPQC considering VA loading and maximum utilization of power-electronic converters. *IEEE Transactions on Power Delivery*, 29(3), 1490–1498. <https://doi.org/10.1109/TPWRD.2013.2295857>
- [10] Khadem, S. K., Member, S., Basu, M., & Conlon, M. F. (n.d.). *Integration of UPQC for Power Quality Improvement in Distributed Generation Network – A Review*.
- [11] Conference, I., Technologies, E., & Viji, J. (2012). Generalized UPQC system with an improved Control Method under Distorted and Unbalanced Load Conditions. 193–197.
- [12] Member, G. D. A. S., Member, D. D. G., Faranda, R., & Member, H. H. S. (2015). Open UPQC Power Quality Manager within Distributed Generation Systems. 501–507.
- [13] Ye, J., Gooi, H. B., Member, S., & Wu, F. (2018). Optimal Design and Control Implementation of UPQC Based on Variable Phase Angle Control Method. 3203(c), 1–14. <https://doi.org/10.1109/TII.2018.2834628>
- [14] Khadkikar, V., & Chandra, A. (2008). A new control philosophy for a unified power quality conditioner (UPQC) to coordinate load-reactive power demand between shunt and series inverters. *IEEE Transactions on Power Delivery*, 23(4), 2522–2534. <https://doi.org/10.1109/TPWRD.2008.921146>
- [15] Khadkikar, V. (2012). Enhancing electric power quality using UPQC: A comprehensive overview. *IEEE Transactions on Power Electronics*, 27(5), 2284–2297. <https://doi.org/10.1109/TPEL.2011.2172001>