

# Review on Contingency and its Effects in Transmission Lines

Jayprakash Giri  
M. Tech Scholar  
Gyan Ganga Institute of  
Technology & Science  
Jabalpur, M.P., India  
girijay11@gmail.com

Sh. Rajiv Chauhan  
HOD, Electrical Engineering  
Gyan Ganga Institute of  
Technology & Science  
Jabalpur, M.P., India

Smt. Nidhi Mishra  
Professor  
Gyan Ganga Institute of  
Technology & Science  
Jabalpur, M.P., India

**Abstract:** A component failure in a power system is known as a contingency. The system must return to an acceptable state of equilibrium after the contingency. Post-contingency correction factors are important for maintaining reliability. Correction factors require analysis of contingent liabilities. Various methods are used to perform contingency analysis. Control of the transmission system has been described in this document. The pricing conditions and associated parameters for the different types of transmission lines have been described. The article focuses on all the parameters necessary for the analysis of transmission systems and their limits.

**Keywords:** Contingency Analysis, EMS, transmission line, distributed system.

## I. INTRODUCTION

Emergency analysis is one of the main components of modern energy management systems. To be able to quickly estimate system stability immediately after failures, efficient system performance calculations based on a set of simplified system conditions are performed during the contingency analysis review [1]. Emergency analysis is one of the most important tasks of engineers in the planning and operation of mass power systems. The Line Failure Distribution Factor (LODF) is one of the important linear sensitivity factors that plays a key role in determining the impact of critical contingencies and therefore suggests possible preventive and corrective actions to resolve system violations. LODFs are used to estimate the change in speed on one line caused by the failure of a second line. Typically, they are only used to determine the MW rate change from the pre-emergence rate. LODFs are approximately independent of flows, but depend on the assumed topology of the network [2]. Power Transfer Distribution Factors (PTDFs) show the linear Zed effect of power transfer.

The growing load demand in power supply systems without accompanying investments in generation and transport has had an impact on the analysis of stability phenomena and requires more reliable and faster tools [1-2].

### A. Contingency Analysis

Emergency Analysis is one of the "safety analysis" applications in a utility control center that distinguishes an energy management system (EMS) from a minor SCADA system. The goal is to analyze the electrical system in order to identify overloads and problems that may arise due to a "contingency". Emergency scan is an abnormal condition of the electrical network. This puts a strain on the whole system or part of the system. This happens due to the sudden opening of a transmission line. Starting the generator. Sudden generational change. Sudden change in the carrying amount. Contingent Analysis provides tools for managing, creating, analyzing and reporting lists of contingent liabilities and related infringements [3].

CA is used as a study tool for offline analysis of emergency events and as an online tool to show operators the impact that future outages would have.

Safety is determined by the system's ability to withstand equipment failure.

Weak elements are those that show overload in emergency conditions (overload).

The standard approach is to run a single contingency analysis simulation (N-1).

A classification method is demonstrated for prioritizing transmission planning [4].

The CA is therefore a main tool for creating the annual maintenance plan and the corresponding grid outage plan.

### B. Types of Violations

Line Contingencies and Generator Contingencies are generally the most common types of contingent liabilities. These dangers mainly cause two types of failures.

#### a. Low Voltage Violations –

This type of violation occurs on buses. This indicates that the bus voltage is below the specified value. The operating

voltage range on each bus is typically 0.95 to 1.05 p.u. So when the voltage drops below 0.95 p.u, the bus is low voltage. If the voltage exceeds 1.05 p.u, the bus has a high voltage problem. Reactive power is known to generally cause voltage problems in the electrical network. Therefore, in the event of low voltage problems, reactive power is supplied to the bus to increase the voltage profile on the bus. In the event of a high voltage, reactive power is drawn on the buses to maintain normal system voltage.

#### b. Line MVA Limits Violations –

This type of contingency occurs in the system when the MVA size of the line exceeds the specified size. This is mainly due to the increase in the amplitude of the current flowing in this line. The lines are designed in such a way that they can withstand 125% of their MVA limit value. Based on power supply practices, the current is declared as an alarm condition if it exceeds 80-90% of the limit value. Different types of countermeasures to solve this problem are discussed later in this document. [5].

## II. LITERATURE REVIEW

Swaroop N S1 et al. [6] In this article, the quickly decoupled current stream strategy is utilized for possibility order of the force framework in case of a line issue dependent on the dynamic force list and voltage power list. The positioning outcomes from the complete force record, which is the amount of the dynamic force and the voltage power file, The proposed strategy is executed on the 400 kV Karnataka power transmission lattice utilizing the MiPower apparatus.

Ming Chen et al. [7] this report presents the redefinition of perils and their application to the wellbeing examination of electrical frameworks. Possibility Analysis (AC) has been a significant apparatus in arranging and dissecting electrical force frameworks for a long time. In view of ongoing organization availability, the supersede work considers the genuine reaction of the security subsystem to the electrical organization hardware. Distinguish the circuit breakers expected to segregate crisis hardware.

Ramandip S et al. [8] a demonstrating approach portrayed in this report gives a one of a kind method to distinguish trigger occasions that can prompt falling blunders. It predicts the development of falling occasions by recognizing and showing potential falling levels. The proposed approach was executed utilizing a worked on conveyance network with 12 transports. The consequences of the investigation show that trigger occasions and conceivable falling chains can be recognized, grouped and envisioned. This methodology can be utilized to improve the dependability of a transmission arrange and diminish its weakness to falling interferences.

Mark K. Enns et al. [9] This report depicts a straight possibility examination program that figures linearized varieties in real force stream coming about because of organization disappointments and changes in age or burden. A cutting edge definition depended on the relationship  $\Delta P = \Delta \theta$  instead of utilizing current infusions and transport input framework. For a most extreme preparing rate of countless possibilities, the express reversal (three-sided a piece) of H is determined by the retrogressive replacement technique.

## III. TRANSMISSION LINES

Transmission lines are gadgets intended to carry power starting with one point then onto the next. These lines are utilized to communicate the RF energy yield from a transmitter to a receiving wire. Energy couldn't stream effectively through ordinary electrical cables (without huge misfortunes). Albeit the radio wire can be pointed straightforwardly at the transmitter, it is found one square from the transmitter. On board the boat, the transmitter is situated in a radio room and the receiving wire is introduced on a pole. The two gadgets are associated through a transmission line. The primary motivation behind the transmission line is something very similar for the transmitter and the radio wire. The objective is to convey the yield energy from the transmitter to the radio wire with insignificant force dispersal. The adaptability of transmission lines is profoundly reliant upon the particular electrical (obstruction and impedance) and actual properties of transmission lines.

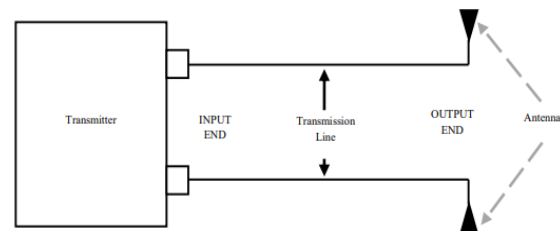

Fig. 1 simple transmission line

The transmission line has two completed finishes. One of these lines prompts a source base, which is generally alluded to as the info end or generator end. These are additionally alluded to as sending reason, sending reason or beginning. The opposite finish of the transmission line is associated with the radio wire and is known as the yield end or the less than desirable end. It is otherwise called a sink filler or end.

## IV. CLASSIFICATION OF TRANSMISSION LINES

The transmission line can be examined with the three constants; R (resistance), L (inductance) and C (capacitance). These factors are evenly distributed over the entire length. Inductance and resistance are the two factors that make up the series impedance. The capacitance that exists between the

conductors for a solitary stage line or from the conductor to impartial conductor for the three stage line frames a branch way along the length of the line. Subsequently, capacitance impacts add entanglements to transmission line estimations. Overhead lines are arranged dependent on the presence of limit in a line.

A. Short Transmission Lines

Overhead lines up to a radius of approximately fifty kilometers and lower line voltage (<20 kV) are considered part of the short transmission line. Due to the low voltage and shorter length, the capacitance effects are small enough not to disturb the transmission, which is why they are neglected. Therefore, only the resistance and inductance of the line are taken into account.

B. Medium Transmission Lines

Transmission lines in the range from fifty to one hundred and fifty kilometers, which carry voltage in the range  $20 < V < 100$  kV, are considered the average transmission range. Because of this length and strain, the capacitance impacts show a solid impact in the line and should subsequently be considered. With the end goal of the computation, the conveyed capacitance is circulated in the line and summed up as capacitors, which are spanned at least one focuses on the line.

C. Long Transmission Lines

The long-life transmission line is used for overhead lines with a range of more than 150 km and a grid voltage greater than 100 kV. To cope with such a large scale, line constraints are evenly distributed over the entire length and rigorous methods are used for resolution purposes. We can also say that the exact solution for long-range transmission lines takes into account the fact that the line constants are not aggregated and uniformly distributed over the length of the line. However, if these constants are taken together for medium and short range transmission lines, reasonable accuracy can be achieved.

V. LOSSES IN TRANSMISSION LINES

The electricity produced in power plants circulates through large and complex networks such as overhead lines, transformers, cables and other devices and reaches end users. It is a fact that the single unit of electricity produced by the plant does not correspond to the units that are distributed to consumers. However, a certain percentage of the units are lost in the distribution network.

$$\frac{\text{Transmission and Distribution Losses}}{\text{Energy Input to Feeder (Kwh)}} - \frac{\text{Billed Energy to consumer (Kwh)}}{\text{Energy Input Kwh}} \times 100 =$$

Some of the major transmission losses are mentioned here. There are two types of technical losses. Fixed and variable.

A. Fixed Losses

- Fixed losses do not vary with current. These losses are in the form of heat and noise and occur while a transformer is powered.
- Between 1/4 and 1/3 of technical losses in distribution networks are fixed losses. Fixed losses in a network can be affected as described below
- Corona losses
- Leakage current losses
- Dielectric losses
- Losses to a minimum
- Losses due to a permanent load on the measuring elements
- Losses due to constant use of control elements.

B. Variable Losses

These vary with the amount of current delivered into the line and are proportional to the square of the current. Consequently, an increase in current of 1% results in an increase in losses of more than 1%.

- Between 2/3 and 3/4 of the technical (or physical) losses of the distribution networks are variable losses.
- Increasing the cross section of wires and cables for a given load reduces losses. This leads to a direct trade-off between loss costs and investment costs. Some researchers have suggested that the optimal average utilization rate in a distribution network, taking into account the cost of losses in its design, could be as low as 30%.
- Joule losses in the lines at any voltage level
- Loss of impedance
- Losses due to contact resistance.

VI. LOAD BALANCING

The load balancing in the appropriation network is characterized so that the heap flows in the three periods of the circulation organization of the power network remain significantly unaltered during the whole working time. In the pragmatic dispersion organization, some force supplies are over-burden and others daintily stacked. For load adjusting, we need to move loads from intensely stacked branches to softly stacked branches, for instance by meeting a few objectives. B. Keep up negligible execution misfortune in the framework. Burden adjusting likewise improves the unwavering quality and security of the dissemination framework.

The power dissipated in the distribution system can be mathematically expressed as follows:

$$\sum_{i=1}^n r_i \frac{P_i^2 + Q_i^2}{|V_i|^2} \tag{1}$$

where  $P_i$  is active power,  $Q_i$  is reactive power and  $r_i$  is resistance of branch  $i$ , and  $n$  is the total number of branches in the system [10]. The force misfortunes rely upon the dynamic and responsive influence streams connected to the associated dynamic and receptive burdens. With ideal burden adjusting, stage voltages and stage flows are almost something similar in each stage subject to acceptable warm cutoff points.

VII. LOAD BALANCING PROBLEM FORMULATION

Load unbalance is the main problem in many applications where the load is unevenly distributed among the collectors. The load balancing problem can be formulated in several ways. The problem comes in the form of system load and branch load indices with which the total system load or branch load is measured [11]. The System Load Balancing Index (LB<sub>sys</sub>) is defined as,

$$LB_{sys} = \frac{1}{nb} \sum_{i=1}^{nb} \frac{S_i}{S_i^{max}} \tag{2}$$

where  $nb$  is the total no of branches,  $S_i^{max}$  is the rating of branch  $i$  and  $S_i$  is the apparent power in branch  $i$ . Branch load balancing index (LB<sub>i</sub>) is defines as

The issue is upgraded if the framework burden and all branch load files are equivalent [2]. In [12], the equivalent is planned in the detailing of the correspondence of connection. That is, the proportion of the force gadget burden to the force gadget limit ought to be equivalent to the proportion of the general framework burden to the general framework limit. Organization reconfiguration issues for load adjusting can be defined considering a little dissemination network as in [12]. In a large portion of the examination led to date, the appropriation framework has been seen as a three-stage, four-wire framework to perform load adjusting. With the end goal of the investigation, consider a little dissemination network with the control switches as demonstrated in Fig. 1.

$$LB_i = \frac{S_i}{S_i^{max}} \tag{3}$$

The issue is advanced if the framework burden and all branch load records are equivalent [5]. In [13], the equivalent is detailed as corresponding uniformity. that is, the proportion of the force gadget burden to the force gadget limit ought to be equivalent to the proportion of the general framework burden to the general framework limit. Organization

reconfiguration issues for load adjusting can be detailed considering a little dispersion network as in [14]. In a large portion of the examination directed to date, the dispersion framework has been seen as a three-stage, four-wire framework to perform load adjusting. For investigation purposes, consider a little conveyance network with control switches as demonstrated in Figure 2.

Considering the reconfiguration of the dissemination network for load adjusting, the issue is defined so that the principle objective is to recognize the open/close places of the switches so the heap offsetting should be possible with a relating change of switch positions between stages.

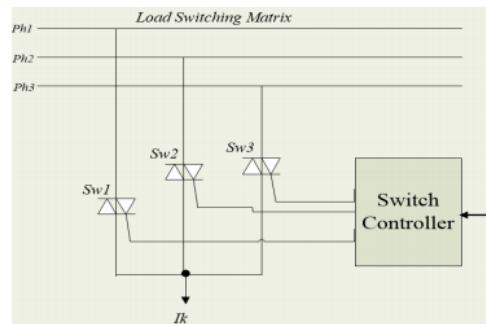

Fig. 2. Small distribution network with switches

The following assumptions are made before performing load balancing:

- i. The radial configuration of the distribution system must be maintained even after load balancing.
- ii. The connected load is in an asymmetrical state and must be known.
- iii. All charges must be met

The objective is accordingly to give load adjusting to the appropriation network by diminishing the framework power misfortune without abusing the voltage and current constraints of the influence supplies.

VIII. CONCLUSION

Conventionally, the safety of the electricity network is guaranteed by an emergency analysis of the transport network (TS). The distribution system (DS) is considered a fixed or variable aggregate load at the point on the interconnect bus where the load quantum indicates the DS power demand from the network. However, this demand will no longer be satisfied by the spread of decentralized production based on renewable energy. Control of the transmission system has been described in this document. The associated state of charge and parameters for different types of transmission lines have been described. The analysis of the DS, which is powered by the various renewable energy

sources, constitutes a broad field of research for the analysis of the load in these systems.

#### REFERENCES

- [1] Chia-Chi Chu, Sheng-Huei Lee, & Husun-Yuan Chuang "Efficient Look-Ahead Load Margin and Voltage Profiles Contingency Analysis Using the Tangent Vector Index Method". Department of Electrical Engineering, Chang Gung University Kwei-San, Tao-Yuan 333, Taiwan, R.O.C.
- [2] T. Guler, G. Gross, M. Liu, "Generalized Line Outage Distribution Factors", Power Systems, IEEE Trans. Vol. 22, Issue 2, May 2007, pp.879 – 881.
- [3] K. Bhattacharya, M. Bollen, and J. Daalder, Operation of Restructured Power Systems (Kluwer Academic Publishers, 2001).
- [4] Loi Lei Lai, Power System Restructuring and deregulation (John Wiley & Sons, 2002).
- [5] K. Radha Rani, J. Amarnath, and S. Kamakshaiyah, "Contingency Analysis under Deregulated Power Systems", ICGST-ACSE Journal, Volume 11, Issue 2, November 2011.
- [6] Swaroop N S1, Lekshmi M "Contingency Analysis And Ranking On 400 Kv Karnataka Network By Using MIPOWER", International Research Journal of Engineering and Technology (IRJET), Volume: 03 Issue: 10 | Oct -2016.
- [7] Ming Chen, "Contingency Redefinition and its Application to Power System Security Analysis", IEEE Conference on Power Systems Conference and Exposition, 2011, pp. 1-4.
- [8] Ramandip S, Jaspreet Singh "Power System Security Using Contingency Analysis for Distributed Network" volume 02, issue 04 (april 2013).
- [9] Mark K. Enns, John J. Quada "Fast Linear Contingency Analysis", IEEE Transactions on Power Apparatus and Systems, Volume: PAS-101, Issue: 4, April 2013.
- [10] W. M. Siti, A. A. Jimoh and D. V. Nicolae, "Load balancing in distribution feeder through reconfiguration," 31st Annual Conference of IEEE Industrial Electronics Society, 2005. IECON 2005, pp.263-268.
- [11] K. Mansouri, M. Ben Hamed, L. Sbita and M. Dhaoui, "Three-phase balancing in a LV distribution smart-grids using electrical load flow variation: "L.F.B.M.", 2015 16th International Conference on Sciences and Techniques of Automatic Control and Computer Engineering (STA), 2015, pp. 427-431, Monastir.
- [12] M.A Kashem, V Ganapathy, "Three-phase load balancing in distribution systems using index measurement technique," International Journal of Electrical Power & Energy Systems, Vol. 24, Iss. 1, pp.31-40, 2002.
- [13] M. Li, P. He and L. Zhao, "Dynamic Load Balancing Applying Water-Filling Approach in Smart Grid Systems," in IEEE Internet of Things Journal, vol. 4, no. 1, pp. 247-257, Feb. 2017.
- [14] M. W. Siti, A. A. Jimoh and D. V. Nicolae, "Phase load balancing in the secondary distribution network using fuzzy logic," AFRICON 2007, Windhoek, pp. 1-7, 2007.