

Fault Analyzer Circuit Analysis at the Load Line in Hybrid Solar/Wind System

Pankaj Mohan Nautiyal
M.tech scholar
Lakshmi Narayan College of Technology
Bhopal (M.P) India
pankajnautiyal1990@yahoo.com

Mr. Rohit Kumar Verma
Assistant Professor
Lakshmi Narayan College of Technology
Bhopal (M.P) India
rohitv@lncet.ac.in

Abstract: Electric power is generated, transmitted, and distributed via large interconnected power systems. The generation of electric power takes place in a power plant. The main objective reduces the operating time of fault current removal from the load line and senses the fault current quickly to overcome its effects. The system is to be made effective and efficient while dealing with the fault situation, fault removal, and restoration of the normal operating conditions at the loading points. The results conclude the effectiveness of the proposed T-ACO-based Optimization control for the operation of the relay in accordance with the fault current limiter and analyzer circuit. The second model of the hybrid system concludes that the system having fault current limiter and analyzer circuit reduces and fault current rise and prevents the voltage from dropping to zero even if no AI-based technique is used and the operating time remains the same. The AI-based techniques further reduce the operating time also thereby making the system more efficient as the voltage is restored to its normal value in a short interval of time when the test system is simulated for 1 second in a MATLAB/SIMULINK environment.

Keywords: DC, VSC, LVRT, fault analysis, PV.

I. INTRODUCTION

Electric power is generated, transmitted and distributed via large interconnected power systems. The generation of electric power takes place in a power plant. Then the voltage level of the power will be raised by the transformer before the power is transmitted. Electric power is proportional to the product of voltage and current this is the reason why power transmission voltage levels are used in order to minimize power transmission losses. During normal operating conditions, current will flow through all elements of the electrical power system within pre-designed values which are appropriate to these elements' ratings. Any power system can be analyzed by calculating the system voltages & currents under normal & abnormal scenarios. A falling tree on a transmission lines could cause a three-phase fault where all phases share a point of contact called fault location. A fault can be defined as a massive current passing through the wrong path that can cause enormous damage to the equipment, resulting in power outages, personal injury or death. Also, the voltage level

changes, which if increased can affect the insulation of the device or cause the device to fail to start if the voltage is below a minimum level. The electrical potential difference of the system neutral will increase [2]. Hence, People and equipment will be exposed to the danger of electricity which is not accepted.

II. LITERATURE REVIEW

Pedro M.Almeida et al. [1] this article proposes a new type of discrete time voltage regulator on the DC side for voltage converters connected to the grid in the event of asymmetrical faults. The main objective is to eliminate the oscillation of the second order voltage on the DC side of the VSC as well as the injection of third order harmonic current into the network in case of asymmetrical faults.

Xianbo Wang et al. [2] The new energy community has recently seen an increase in developments in photovoltaic generation technologies. In order to meet the grid code requirements of a low voltage transition solar PV inverter (LVRT), this document aims to control both negative sequence current suppression and grid side reactive power fluctuations using grid voltage asymmetry to maintain a balanced inverter output. Simulations and experimental results confirmed the superior effectiveness of our proposed control strategy.

Liqun Shang et al. [3] In order to meet the low voltage continuity (LVRT) requirements of a grid connected PV inverter under certain circumstances where the three-phase grid voltage has asymmetrical drops, a grid connected inverter imbalance control strategy is developed. in this document. A simulation model for grid-connected photovoltaic systems is created in Matlab / Simulink. The simulation results show that the proposed LVRT operation can be implemented under unbalanced grid voltage conditions.

A. Safa et al. [4] This article offers a robust control algorithm for Grid Connected Multifunctional Inverter (MFGTI) for Photovoltaic (PV). The MFGTI is used to simultaneously supply the active power of a photovoltaic module and improve the energy quality of a microgrid. The proposed algorithm estimates the positive fundamental component of the source current even under highly disturbed main voltage and load conditions. With this algorithm, the MFGTI provides active power, compensates for reactive power and improves the power quality of the micro-grid. The main grid then provides only a certain amount of active power with a power factor of one.

III. OBJECTIVE

This thesis will target on the following main objectives:

- Designing of solar/wind hybrid test system in MATLAB/SIMULINK that has to be integrated with the grid energy system and is meant to drive the local loads
- The coordination and control of the relay based in accordance with the fault analyzer and limiter circuit operation by using an efficient artificial based technique specifically for the local loads
- To reduce the operating time of fault current removal from the load line and senses the fault current quickly to overcome its effects.
- The system is to be made effective and efficient while dealing with the fault situation, fault removal and restoration of the normal operating conditions at the loading points.

IV. METHODOLOGY

A. Modeling of hybrid system

Researchers are developing various modeling techniques to model the components of HRES. The performance of the individual components is modeled using deterministic or probabilistic approaches. This chapter discusses the basic modeling structures of solar energy system, and Wind energy system along with modeling of PSS controls.

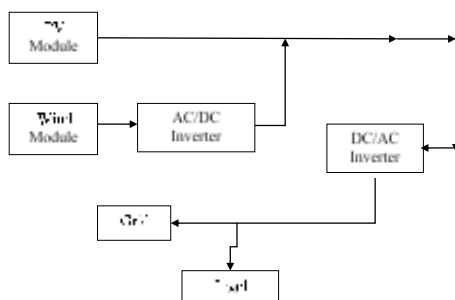

Fig. 1 Proposed Hybrid energy system topology

B. PV Module modeling:

Photovoltaic energy is available in abundance in the environment and without pollution. The type of output power of the photovoltaic system depends on the geographic location. The photovoltaic system is a potential renewable energy source with which it is possible to overcome dependence on fossil fuels [4]. Figure 1 shows the representation of a hybrid PV generation unit consisting of a PV generator, a DG, an inverter and a battery system. Different combinations of photovoltaic / diesel hybrid systems via battery storage and additional DG unit are investigated in order to investigate the potential benefits and efficient use of photovoltaic-diesel systems to meet consumer load needs [5].

Classification of stand-alone and grid-connected PV systems
 Photovoltaic systems are divided into two categories: stand-alone and grid-interactive or grid-connected systems. This classification of PV systems depends on their operational and functional requirements, the configuration of their components and their connection to other electrical loads and power sources. Furthermore, photovoltaic systems can operate autonomously or connected to the electricity grid. They are designed to provide AC and / or DC power and can be connected to energy storage systems and other alternative energy sources. As already mentioned, grid-connected PV systems are designed for parallel operation and connection to the power grid.

The air conditioning unit (PCU) or inverter is the main component of the PV systems connected to the grid that convert the direct current generated by the photovoltaic generator into alternating current that satisfies the voltage and electrical quality requirements of the electrical user network both for direct use on devices that to be sent to the public network. to earn repurchase fee compensation. If the mains is not powered, the PCU automatically cuts off the mains supply.

A two-way interface, located in an on-site distributor or service input, allows the alternating current generated by the PV system to supply electrical loads on site or re-feed into the grid if the power of the PV system is reduced. Greater than The power on site is the load demand. When the electrical loads are higher than the power of the photovoltaic system, especially at night and in cloudy weather, the power balance required by the loads is received by the utility company. It is a safety device in the event of a grid failure for maintenance or repair purposes to ensure that the photovoltaic system is no longer in use and returns to the grid [9].

A grid-connected photovoltaic system without emergency energy storage (ES) is environmentally friendly and is often used by people due to lower maintenance requirements and

costs. However, in the event of a power failure during the night or on a cloudy day, the system should shut down until mains power is available. Grid-connected photovoltaic systems with a backup IO are generally grid-connected. This configuration offers several advantages, such as: For example, selling excess PV generation to the grid, charging the battery system during off-peak hours, and buying electricity from the grid to power the loads when charging battery is insufficient. Renewable PV sources cannot provide a constant supply of energy and create a potential imbalance between production and demand, especially during off-peak periods when PV generates more energy and during peak periods when load demand increases too much.

Photovoltaic cells have a single operating point where the current (I) and voltage (V) values of the cell lead to the maximum output power. These values correspond to a certain resistance equal to V / I. A simple equivalent circuit of PV cell is shown in Fig. 2.

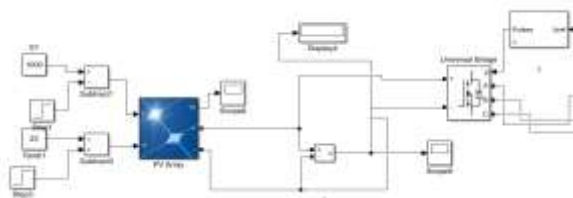

Fig. 2 Modeled solar system

A cell series resistance (Rs) is connected in series with parallel combination of cell photocurrent (I_{ph}), exponential diode (D), and shunt resistance (R_{sh}), I_{pv} and V_{pv} are the cells current and voltage respectively. It can be expressed as

$$I_{pv} = I_{ph} - I_s(e^{q(V_{pv} + I_{pv}R_s)/nKT} - 1) - (V_{pv} + I_{pv} * R_s)/R_{sh} \quad \text{Eq (1)}$$

Where:

- I_{ph}- Solar-induced current
- I_s - Diode saturation current
- q - Electron charge (1.6e⁻¹⁹C)
- K - Boltzmann constant (1.38e⁻²³J/K)
- n - Ideality factor (1~2)
- T - Temperature ⁰K

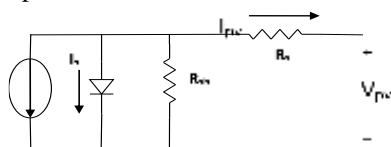

Fig. 3 Equivalent circuit of solar PV cell

The solar induced current of the solar PV cell depends on the solar irradiation level and the working temperature can be expressed as:

$$I_{ph} = I_{sc} - k_i(T_c - T_r) * \frac{I_r}{1000} \quad \text{Eq (2)}$$

Where:

- I_{sc} Short-circuit current of cell at STC
- K_i Cell short-circuit current/temperature coefficient (A/K)
- I_r Irradiance in w/m
- T_c, T_r Cell working and reference temperature at STC

A PV cell has an exponential relationship between current and voltage and the maximum power point (MPP) occur at the knee of the curve as shown in the Fig 4.

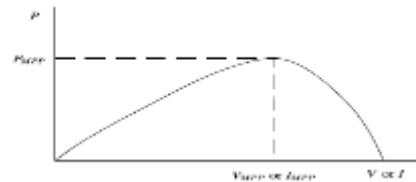

Fig. 4 Characteristic PV array power curve

Table 1 PV module Parameters

Model	1Soltech 1STH
Maximum Power	213.5 Watts
Number of parallel strings	40
Number series modules	10
Open circuit voltage	36.3 Volts
Shot circuit current	7.84 Ampere
Irradiation	1000 wb/m ²
Temperature	30°C

C. wind energy system modeling

Wind energy is also freely available in environment, pollution free source of energy. The performance of the output power generation of wind energy system varies according to the wind potential of design location. The condition for feasible solution and techno-economic wind energy system is the selection of higher wind energy potential geographical location is necessary [6]. The feasible and economical model of the wind system is examined to compare the performance of different wind turbines in different places with respect to the average speed and properties of the turbine machine [6].

1 Generator

Wind energy spins two or three propeller blades around a rotor. The rotor is connected to the main shaft, which spins a generator to generate electricity. The generator thus converts the mechanical energy of the wind turbine rotor into electrical energy

The model of a wind turbine with PMSG wind turbines is not able to fully capture wind energy. The components of the wind turbine were modeled by the following equations [1-5].

D. Output aerodynamic power of the wind-turbine is expressed as:

$$P_{Turbine} = \frac{1}{2} \rho A C_p(\lambda, \beta) v^3 \quad \text{Eq (1)}$$

where, ρ is the air density (typically 1.225 kg/m³), A is the area swept by the rotor blades (in m²), C_p is the coefficient of power conversion and v is the wind speed (in m/s).

The tip-speed ratio is defined as:

$$\lambda = \frac{\omega_m R}{v} \quad \text{Eq (2)}$$

where ω_m and R are the rotor angular velocity (in rad/sec) and rotor radius (in m), respectively.

The wind turbine mechanical torque output mT given as:

$$T_m = \frac{1}{2} \rho A C_p(\lambda, \beta) v^3 \frac{1}{\omega_m} \quad \text{Eq (3)}$$

The power coefficient is a nonlinear function of the tip speed ratio λ and the blade pitch angle β (in degrees).

Then Power output is given by

$$P_{Turbine} = \frac{1}{2} \rho A C_{p_{max}} v^3 \quad \text{Eq (4)}$$

A generic equation is used to model the power coefficient C_p based on the modeling turbine characteristics described in [2], [7-9] and [11] as:

$$C_p = \frac{1}{2} \left(\frac{116}{\lambda_i} - 0.4\beta - 5 \right) e^{-\left(\frac{21}{\lambda_i}\right)} \quad \text{Eq (5)}$$

For each wind speed, there exists a specific point in the wind generator power characteristic, MPPT, where the output power is maximized. Thus, the control of the WECS load results in a variable-speed operation of the turbine rotor, so the maximum power is extracted continuously from the wind.

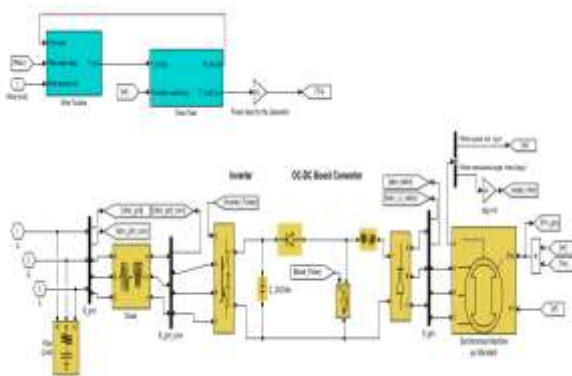

Fig. 5 modeled Wind system

This mechanism uses the variable torque output w_m and tries to optimize the output current and voltage waveform to its maximum value.

Table 4.2 :Wind energy system parameters

Wind speed	11 m/sec
Number of wind turbines	80
Nominal power	2 MW
Frequency	50 hertz

Line to line voltage	410 V
Friction factor	0.01
Number of poles	1
Inertia constant	0.62

E. Modeling Proposed fault analyzer and limiter circuit

The increase in the power generation capacity of power systems has led to an increase in the fault current level, which can exceed the maximum designed short-circuit values of the switchgear. Many conventional protection devices installed to protect against excessive residual currents in power systems, especially in power plants, are circuit breakers that are activated by an overcurrent protection relay.

Usually, the non-inductive winding consists of a two-wire spiral or other arrangement of pancakes. Furthermore, a loose superconducting tube cut adequately on the surface to create a current path similar to that of a two-wire coil can be used to create a resistive fault current limiter [9].

To avoid the risk of hot spots, the superconductor must be in contact with a normally conductive matrix (as in the case of BSCCO and MgB2 composite tapes or wires) or a branch layer (as in the case of conductors coated with YBCO or BSCCO tubing). The role of the matrix or shunt layer is to promote uniform propagation of the quench; therefore, they have a high thermal and electrical conductivity.

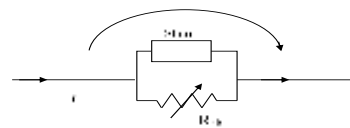

Fig. 6 Circuit scheme of a proposed fault current analyzer and limiter circuit

A circuit scheme of proposed circuit is shown in figure 1.5. Nonlinear resistance RSC is given by the parallel equivalent of the superconductor and the normally conductive shunt matrix or layer. The presence of the low resistivity material allows only a low value of the equivalent resistance even after a complete transition.

F. PSO algorithm

Particle swarm optimization PSO is a novel swarm optimization algorithm that is firstly proposed by Kennedy as an evolutionary algorithm based on behavior of birds. PSO uses a set of particles that each one suggests a solution to the optimization problem. It is based on the success of all particles that emulates a population where the position of each particle depends to the agent position to detect the best solution P_{best} by using current particles in the population G . The position of any particle x_i is adjusted by

$$x_i^{k+1} = x_i^k + v_i \quad (1)$$

where the velocity component v_i represents the step size and is calculated by:

$$v_i^k = wv_i^k + c_1r_1(P_{best_i} - x_i^k) + c_2r_2(G - x_i^k) \quad (2)$$

where w is the inertial weight, c_1 and c_2 are the acceleration coefficients, r_1 and r_2 are random values that belong to the interval of $[0, 1]$, P_{best_i} is the best position of particle i , and G is the best position in the entire population.

The operation given in flowchart can be analyzed in five steps that are initialization, fitness evaluation, updating the individual and global best value, updating the velocity and position of each particle, and convergence determination. In the first step, particles are randomly initialized in the distribution space, or are initialized on described grid nodes covering the search space.

Similarly, the initial velocity values are defined randomly. The fitness value of each particle is evaluated in the second step where the fitness evaluation is led to provide candidate solution to the objective function. The individual and global best fitness values are determined in the third step where p_{best_i} and g_{best} are respectively determined.

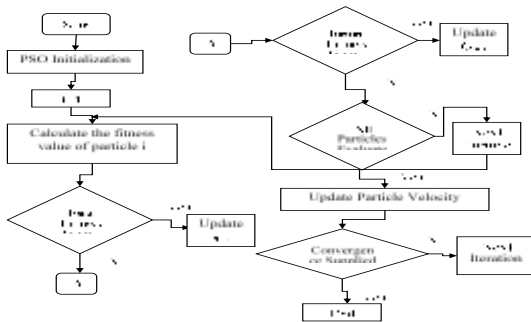

Fig. 7 PSO- controller Technique implemented in MATLAB/SIMULINK

Then the positions are updated and replaced with better fitness values if they are found. The velocity and position of each particle are updated in the fourth step. The last step of the flowchart checks the convergence criterion. If the criterion is met, the process is finished. Otherwise, the iteration number is increased and procedure returns to step 2.

G. ACO algorithm

ACO is a discrete combinatorial optimization algorithm based on the collective behavior of ants when searching for food. An anthill is claimed to be able to find the shortest path from its nest to a food source via an indirect form of communication in which a chemical called a pheromone is deposited on the paths in its path. Over time, shorter and more desirable pathways are supplemented with greater amounts of pheromones, making it the dominant path for the colony.

ACO is a metaheuristic algorithm in which a colony of artificial ants works together to find good solutions to various static and dynamic optimization problems in discrete and continuous domains. It assigns computing resources to a set of relatively simple means (i.e., artificial ants) that communicate indirectly via a trail of pheromones. It is a multi-agent probabilistic algorithm that uses a probability distribution for

the transition between iterations. However, Ant algorithms are particularly effective in solving discrete combinatorial optimization problems. Its successful application in the continuous research space has been widely reported.

In ACO algorithms, the optimization search process is performed by the number of artificial ants moving in a diagram in the search area. Artificial ants are stochastic construction means that form solutions by moving the construction graph. In fact, their constructive aspects distinguish ACO algorithms from other optimization algorithms. Each ant creates its own solution or component based on a predefined initial state. In addition to creating its own solution, each ant collects information on both the characteristics of the problem and its performance. This information is used to change how the problem is presented by other ants. Each ant constructs a solution by moving through a finite sequence of neighboring states.

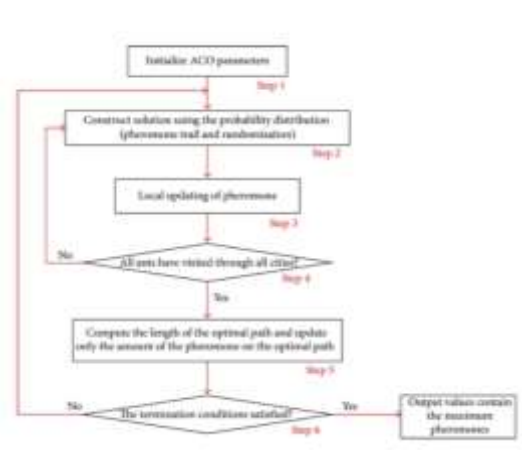

Fig. 8 ACO

Motions are selected using a local stochastic search policy guided by (1) private information and (2) publicly available pheromone traces and 1. default local information specific to the problem. The pheromone trace encodes long-term memory throughout the entire ant search process and is maintained by the ants themselves. On the other hand, heuristic value, often called heuristic information, represents a priori information about the instance of the problem or information about the execution provided by a source other than ants. The ACO is divided into three main phases:

- (1) Solution construction,
- (2) Pheromone updating, and,
- (3) Daemon action.

In the solution construction phase, artificial ants traverse the neighboring states of a problem according to a transition rule and construct solutions iteratively. In the pheromone update stage, the pheromone trace is updated by both improving the

pheromone traces and evaporating the pheromone traces. Daemon actions are an optional step of the algorithm where additional updates are applied from a global perspective, e.g. Promotion of pheromones, resumption of pheromones, etc.

V. RESULTS

A. Implementation Details

This study comprises with an analytical and numerical description of proposed algorithm for sentiment analysis of a power buffer which is simulated to obtain the performance of the proposed algorithm.

In order to evaluate the performance of proposed algorithm scheme, the proposed algorithm is simulated in following configuration:

Pentium Core I5-2430M CPU @ 2.40 GHz

4GB RAM

64-bit Operating System

MATLAB Platform

B. Simulation Environment

MATLAB stands for MATrix LABoratory, which is a programming package exclusively designed for speedy and effortless logical calculations and Input/output. It has factually hundreds of inbuilt functions for a large form of computations and plenty of toolboxes designed for specific analysis disciplines, as well as statistics, optimization, solution of partial differential equations, information analysis.

In this research work MATLAB platform is used to show the implementation or simulation of implemented algorithm performance. Measurement toolboxes are used and some inbuilt functions for generating graphs are used. Simulation results and comparison of the performance of implemented model with some existing ones are calculated by MATLAB functions.

A Hybrid Power System (HPS) utilizes two or more energy sources, power converters and/or storage devices. The main purpose of HPS is to combine multiple energy sources and/or storage devices which are complement of each other. Thus, higher efficiency can be achieved by taking the advantage of each individual energy source and/or device while overcoming their limitations. In this chapter the analysis of the system having hybrid solar/wind energy system with basic voltage source control for the inverter is done.

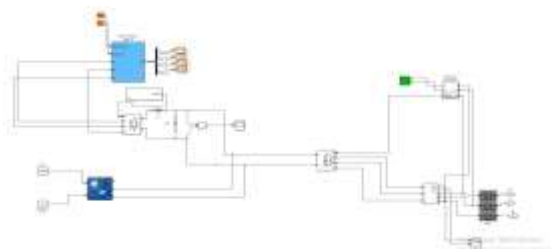

Fig. 9 Hybrid solar/wind three phase system

The solar panel has been modelled with PV arrays having 10 cells connected in each series with 40 parallel branches that together give out the DC output from the system. The illumination of 1000 lux is provided along with temperature of 30⁰ C .This output is then merged with the DC output from the wind energy system and further sent to the inverter for its AC conversion. The DC output waveform have been illustrated in the fig. below.

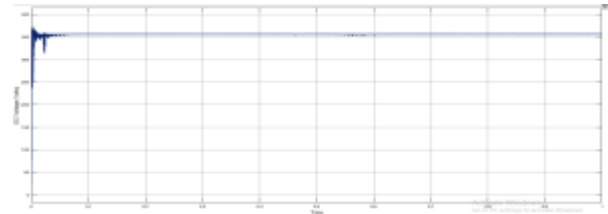

Fig. 10 DC output voltage from the hybrid solar/wind energy system

This work has described the implementation of fault analyzer and removal circuit at the load line in a Solar/Wind hybrid system. The coordination and control of the relay based in accordance with the Fault analyzer operation is done by using various artificial intelligence based algorithms. This work has done a comparative analysis of the Fault analyzer-relay operation with the particle swarm optimization (PSO) and time subjective ant colony optimization (T-ACO).

The system was created to make the comparative analysis and then the best proposed algorithm based relay optimization control along with Fault analyzer circuit was implemented with the Solar/Wind hybrid system.

The chapter discusses the work on the basis of following few descriptions:

CASE 1: Hybrid System modeled without any Fault analyzer circuit in the load line.

CASE 2: Hybrid System modeled with Fault analyzer circuit in the load line but no optimization control for time span.

CASE 3: Hybrid System modeled with Fault analyzer circuit in the load line with PSO technique.

CASE 4: Hybrid System modeled with Fault analyzer circuit in the load line with T-ACO technique.

The relay based Fault analyzer circuit MATLAB/SIMULINK model discusses the response of the relay circuit along with Resistive circuit dissipation when the fault occurs. The proposed system with the time subjective ACO based control of the relay for sensing of the fault current is expected to produce the best outcome that is dissipation of current and Restoration of the normal operation in a short interval of time when the system is subjected to transient instability through LLLG fault in the load line of the solar/wind hybrid system.

To test the operation of the proposed Fault analyzer and dissipater circuit in the three phase load line, the solar hybrid system was studied under the fault condition using various optimization algorithms. For study the simulation time is

selected to be 1 seconds. The three phase fault is created at 0.1 seconds after the start of the simulation.

The circuit consists of one relay circuit along with a breaker. This breaker is expected to operate when the fault occurs to remove the load and save it from the effects of flow of heavy current that persists during the fault. The system is tested for its transient stability before it is incorporated with a Fault dissipation model.

The system response towards the fault and its ability to recover from it is first studied in CASE1. Then the system is made to operate with the fault analyzer circuit without any control algorithm in order to reduce the fault current in the Rsh of the series circuit then an algorithm is so designed that it coordinates its operation with the relay breaker circuit such that it recovers the system from the effects of fault in a minimum interval of time. The entire system is simulated for 1 second in MATLAB/Simulink environment for analysis.

C. CASE 1: Hybrid System modeled without any Fault analyzer circuit in the load line

In this case the hybrid system is independent of the any Fault analyzer and dissipater device and any type of algorithms. The system relay operates after sensing the flow of heavy current in the circuit during the fault condition. The breaker disconnects the load from the supply. The system is studied for its ability to recover from the fault automatically.

The voltage output and current output graphs are being analyzed in the following figures.

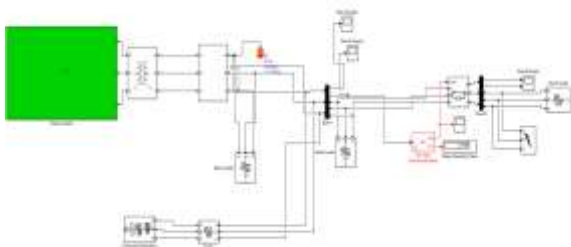

Fig. 11 System modeled without Fault analyzer circuit

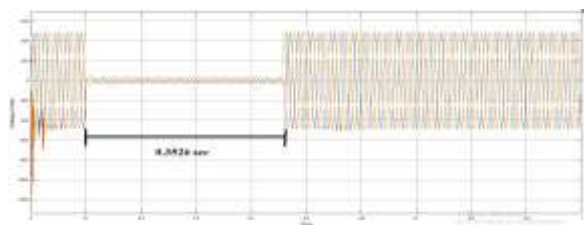

Fig. 12 Voltage output from the System without Fault analyzer circuit

The figure shows the voltage output from the test system having no fault analyzer circuit and control optimization algorithms. The time at which fault occurs the voltage is reduced to approximately 0 Volts zero from 500V load line at local level. This will disconnect the power supply to the local from the hybrid system completely. In order to overcome this

problem we have used the circuit fault analyzer circuit specifically for the load line in the next models as the sudden disconnection of the sources from the grid highly undesirable. Superconducting fault current analyzer and limiter based transient voltage stability scheme is presented for use in hybrid solar/wind farms driven by doubly-fed induction generator (DFIG) during grid faults.

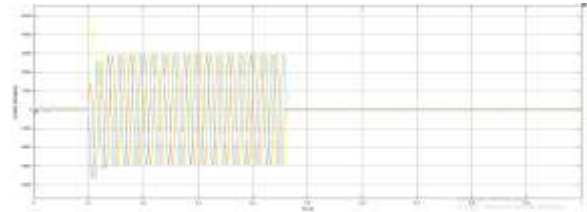

Fig. 13 Current output from the System without Fault analyzer circuit

The figure shows the current output from the system having no Fault analyzer and limiter circuit. When the system is stimulated for one complete second and the fault is generated at 0.1 second in the load line of solar/wind hybrid system we see that current Rises to a heavy value of approximately 3000 amperes. System Ability to remove this fault current is found to be 0.3526 seconds which means that system is able to recover from the fault after this operating time of the relay. The current is again reduced to approximately 50 amperes.

D. CASE 2: Hybrid System modeled with Fault analyzer circuit in the load line but no optimization control for time span.

In this system the source is connected to the load via a Fault analyzer and limiter circuit. The relay breaker circuit is used to protect the load from the effect of heavy current flow when the fault occurs. The fault is created at 0.1 second while the simulation of the system takes place for one second.

The system ability to recover from the fault is almost same as that of the test system in which no Fault analyzer is used. However sudden disconnection of the supply from the grid can be avoided using this device.

To study the effect of Fault analyzer and removal circuit in a hybrid solar/wind system the voltage output and current output waveforms are being analyzed below

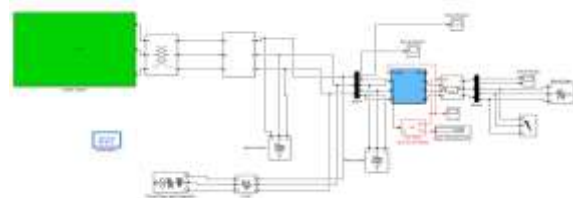

Fig. 14 Hybrid System modeled with Fault analyzer circuit in the load line

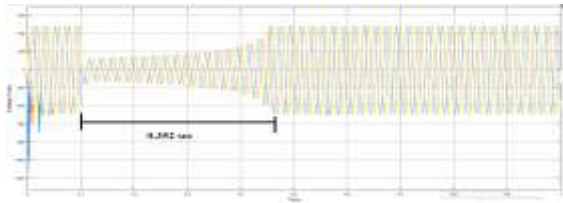

Fig. 15 Voltage output from the Hybrid System modeled with Fault analyzer circuit in the load line Without AI technique

The figure shows the voltage output from the system in which no AI based technique is used for Relay but it consists of the fault analyzer and removal circuit in the load line. When the fault occurs, the value of the voltage decreases abruptly however in a very short interval of time it starts recovering as during this time the current is dissipated in the Rsh (resistance) of Fault analyzer and limiter circuit. As the fault current is reduced, in 0.352 seconds the system resumes its actual operation.

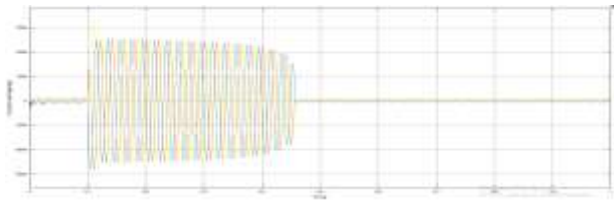

Fig. 16 Current output from the Hybrid System modeled with Fault analyzer circuit in the load line without AI technique

The figure shows the current output waveform in the system modeled with Fault analyzer circuit in the load line without AI technique for coordination control of relay circuit. It is observed that the current Rises to a high value of 28000 ampere at 0.1 second when the fault is created. This heavy current is then made to flow through the Rsh of the Fault analyzer and limiter circuit and hence its value gradually decreases. Finally after a operating time of 0.352 second the system resumes its normal operation and hence the current finally get back to approximately 50 amperes.

From this model it is concluded that both the operation time of the test system in case 1 and the test system in case to is same the voltage instead of getting 0 for the entire time is has recovered to some value due to dissipation of the fault current in the proposed circuit. This model shows the advantage of using a limiter circuit in the grid system. Even if no AI technique is used it is still a better choice to prevent the system from abrupt disconnection during the fault from the source.

E. CASE 3: Hybrid System modeled with Fault analyzer circuit in the load line with PSO technique.

The proposed method employs particle swarm optimization (PSO), an algorithm to search for optimal parameter settings such that the sensing time of the relay and current magnitude as per Rsh such that dissipation is improved. The technique takes the fault current as input and optimizes the time by producing a duty cycle for Fault analyzer circuit triggering and

operation. The voltage is expected to recover from the fault in a less time than the previous case which is produced at 0.1 seconds when the system is simulated for 1 second.

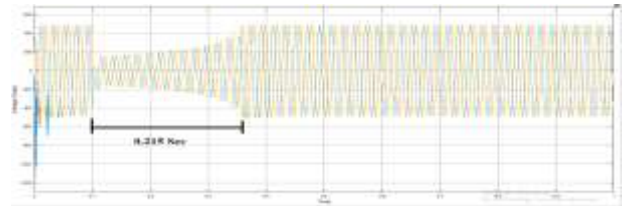

Fig. 17 Voltage output with Fault analyzer circuit in the load line with PSO technique.

The figure shows the voltage output from the system having relay controlled with particle Swarm Optimization technique for its co-ordination control and also improving the fault current detection sensitivity. It has been found that because of employing fault analyzer and limiter circuit, the voltage during the fault current does not reduces to zero and the system transient stability e is enhanced as it is able to recover from the fault in 0.215 seconds.

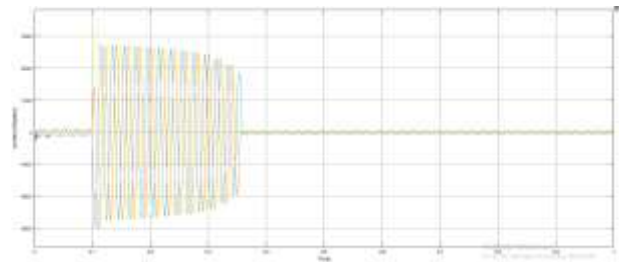

Fig. 18 Current output with Fault analyzer circuit in the load line with PSO technique

The figure shows the current output from the system having PSO based control it has been found that current rises to high value of 2900 A at 0.1 seconds when the fault is created. However the current dissipation takes place in the proposed circuit and the system recovers to its normal operation in a short duration of 0.215 seconds.

F. CASE 4: Hybrid System modeled with Fault analyzer circuit in the load line with T-ACO technique.

This system uses time subjective ACO based optimization technique for its relay based operation. In this model proposed device is used for dissipation of current during fault time. In this system also the fault is created at 0.1 seconds which gets dissipated in a small interval of 0.199 seconds when a ant colony optimization technique is used for relay operation. The technique senses the fault current and optimizes the output by allowing operating time reduction for the dissipation of fault current in the resistive branch of the device. The technique after optimization produces a duty cycle which operates the resistive fault analyzer circuit and directs the current towards it.

This allows reduction in operating time and hence in a short period of time we can recover the voltage from the fault

situation. Hence the system response towards the transient fault it is improved by using this optimization technique in the relay circuit.

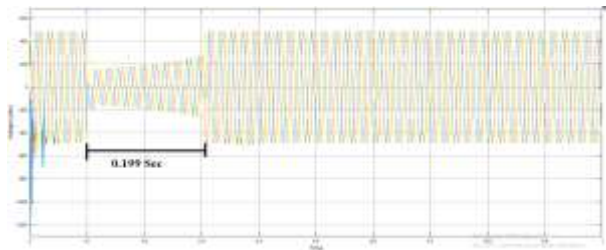

Fig. 19 Voltage output from the Hybrid System modeled with Fault analyzer circuit in the load line with T-ACO technique.

The figure above is depicting the voltage output from the proposed time subjective ant colony optimization (T-ACO) technique for the relay operation. The system voltage gets affected at 0.1 second when the fault is created and it starts rising slowly as the current is dissipated in the proposed fault analyzer resistive circuit. By using this technique the entire procedure takes place in a small interval of 0.199 seconds when the entire system runs for 1 second.

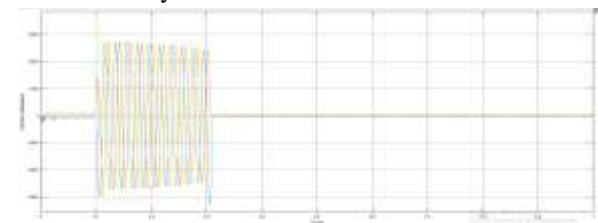

Fig. 20 Current output from Hybrid System modeled with Fault analyzer circuit in the load line with T-ACO technique.

The figure shows the current output from the system having T-ACO based Optimization control for the operation of relay in this condition it has been depicted that it takes about 0.199 seconds for the fault to get removed from the system. The current Rises to a higher amount at 0.1 seconds where the fault is created and it gets dissipated in the shunt resistive branch of the device in a very short time due to this technique. It can be concluded that it is very important to use this circuit in the load line in a hybrid system in order to prevent the sources sudden voltage drop at the load terminal during the faults. The fault current is directed to fault analyzer and limiter circuit so that it gets dissipated in it and the voltage is restored to its normal value. However when the relay breaker circuit control is subjected to an AI based technique which senses the fault current also reduces the operating time of the fault analyzer and limiter circuit and relay circuit. During our research it was found that time subjective ant colony based proposed Optimization technique is found to be best for co-ordination control of the relays and fault limiter based circuits.

VI. CONCLUSION

The fault current levels of an interconnected power network have witnessed a general rise due to increase in power demand.

This rise in fault current if not properly mitigated may exceed the maximum ratings of the switchgear. Fault Current analyzer and Limiter is a flexible alternative to the use of conventional protective devices, due to its effective ways of reducing fault current within the first cycle of fault current, reduced weight and zero impedance during normal operation.

We propose here resistive circuit based fault current analyzer when a fault occurs in a load line (low voltage) in solar PV/Hybrid system specifically. To evaluate the impact of proposed system in the power system, time domain approach is used to evaluate the short-circuit current in the electrical power system and artificial based controlling techniques are being proposed to achieve the objective.

The work has done experiments on a MATLAB/SIMULINK system and studied the effects of proposed fault current analyzer and limiter circuit on it by changing the controlling algorithms for fast sensing and mitigation of fault current in the relay circuit.

The following table concludes the work of the AI based techniques

Test System and Control algorithms	Operating time { seconds }
without fault current analyzer and limiter circuit	0.3526
with Fault analyzer circuit in the load line without AI technique	0.352
Fault analyzer circuit in the load line with PSO technique	0.215
Fault analyzer circuit in the load line with T-ACO technique.	0.199

The above results conclude the effectiveness of the proposed T-ACO based Optimization control for the operation of relay in accordance with fault current limiter and analyzer circuit. The second model of the hybrid system concludes that the system having fault current limiter and analyzer circuit reduces and fault current rise and prevents the voltage from dropping to zero even if no AI based technique is used and the operating time remains the same. The AI based techniques further reduces the operating time also thereby making the system more efficient as the voltage is restored to its normal value in a short interval of time when the test system is simulated for 1 second in MATLAB/SIMULINK environment.

VII. FUTURE SCOPE

Of course, the new type of fault current limiter with different architecture is still under improvement. The work can be further integrated with different architecture for limiter circuit and study its operation. The use of fast switching, forced commutated device like IGBT shunted with a variable resistance, can improve the performance of the system significantly during abnormal conditions. Further the

enhancement of this design can lead to a better output and can make this system to work for low voltage ride through LVRT also.

REFERENCES

- [1] Pedro M.Almeida, Karina M.Monteiro “Improvement of PV grid-tied inverters operation under asymmetrical fault conditions” *Solar Energy*, Volume 133, August 2016, Pages 363-371.
- [2] Xianbo Wang, Zhixin Yang “Control Strategy of Three-Phase Photovoltaic Inverter under Low-Voltage Ride-Through Condition” *Mathematical Problems in Engineering* / 2015.
- [3] Liqun Shang, Weiwei Zhu ; Zhuojun Li “A control method of PV grid-connected inverter under grid voltage unbalanced drops” 2018 Chinese Control And Decision Conference (CCDC), 09 July 2018.
- [4] A.Safa, E. Berkouk, Abdelmadjid Gouichiche “An improved sliding mode controller for a multifunctional photovoltaic grid tied inverter” *Journal of Renewable and Sustainable Energy*, Published 2017.
- [5] Paresh Vinubhai Patel “Modeling and control of three-phase grid-connected PV inverters in the presence of grid faults”, Masters Theses. 7806, 2018.
- [6] Malek, Hadi, "Control of Grid-Connected Photovoltaic Systems Using Fractional Order Operators", All Graduate Theses and Dissertations. 2157, 2014.
- [7] Z. M. Zhao, Y. Lei, F. B. He and Q. Tian, "Overview of large-scale grid-connected photovoltaic power plants", *Automation of Electric Power System*, vol. 35, no. 12, pp. 101-107, 2011.
- [8] Wang Yi-bo ; Liao Hua ; Wu Chun-sheng ; Xu Hong-hua “Large-scale grid-connected photovoltaic power station's capacity limit analysis under chance-constraints” 2009 International Conference on Sustainable Power Generation and Supply, 04 December 2009.
- [9] A. B. Rey-Boué, R. García-Valverde, F. D. A. Ruz-Vila, and J. M. Torreló-Ponce, “An integrative approach to the design methodology for 3-phase power conditioners in Photovoltaic Grid-Connected systems,” *Energy Conversion and Management*, vol. 56, pp. 80–95, 2012.
- [10] F. Blaabjerg, R. Teodorescu, M. Liserre, and A. V. Timbus, “Overview of control and grid synchronization for distributed power generation systems,” *IEEE Transactions on Industrial Electronics*, vol. 53, no. 5, pp. 1398–1409, 2006.