

# Experimental Investigation on Triple Concentric Tube Heat Exchanger with Helical Baffles

Rohit Kumar Gaur

M. Tech Scholar

Technocrats Institute of  
Technology and Science  
Bhopal, M. P, India  
rohitgaur93000@gmail.com

Dr. Shashi Kumar Jain

Professor & HOD, Mechanical  
Department

Technocrats Institute of  
Technology and Science  
Bhopal, M.P, India  
shashi.k.jain@gmail.com

Dr. Sukul Lomash

Professor, Mechanical  
Department

Technocrats Institute of  
Technology and Science  
Bhopal, M.P, India

**Abstract:** A heat exchanger is a device used to transfer thermal energy between two or more liquids, between a solid surface and a liquid, or between solid particles and a liquid at different temperatures and in thermal contact where shell and tube heat exchangers contain a large number of tubes packed in a jacket whose axes are parallel to those of the shell. Heat transfer occurs when one fluid flows into the pipes while the other flows out of the pipes through the jacket. In industry, three-tube heat exchanger tubes are used as condensers, evaporators, sub cooler, heat recovery heat exchangers, etc. The three concentric tube heat exchanger is a constructively modified version of the double concentric tube heat exchanger as an intermediate tube adds some advantages over the double tube heat exchangers in that it is larger tube surface area heat transfer per unit of length. In the present study, the triple tube heat exchanger is further modified by inserting helical baffle over the surface of one of the tubes and observed turbulence flow which may lead to high heat transfer rates between the fluids of heat exchanger. Further, the Reynolds number, Nusselt number, friction factor of the flow at different mass flow rates of the hot fluid while keeping a constant mass flow rate of cold and normal temperature fluids were calculated. It was found that as the mass flow rate of the fluid increases the Reynolds number increases, the turbulence in the flow will increase which will cause the intermixing of the fluid, higher the rate of intermixing, more will be the heat transfer of the system. **Keywords:** heat exchanger, Reynolds number, Nusselt number, friction factor

## I. INTRODUCTION

A heat exchanger is a device used to transfer thermal energy between two or more liquids, between a solid surface and a liquid, or between solid particles and a liquid at different temperatures and in thermal contact. In heat exchangers there are generally no external interactions of heat and work.

Typical applications include the heating or cooling of a fluid stream and therefore the vaporization or condensation of one-component or multi-component fluid streams. In other applications, the goal could also be to recover or reject heat or to sterilize, pasteurize, fractionate, distill, concentrate, crystallize or control a process fluid. In some heat exchangers, the liquids that exchange heat are in direct contact.

Common examples of heat exchangers are shell and tube heat exchangers, car coolers, condensers, evaporators, air preheaters and cooling towers. If there's no phase transition in

any of the heat exchanger liquids, it's sometimes mentioned as a sensitive device. Internal sources of thermal energy are often present in heat exchangers, eg. B. in electric heaters and fuel assemblies. Combustion and reaction can happen inside the heat exchanger, for instance in boilers, combustion heaters and fluidized bed exchangers.

Mechanical devices are often utilized in some heat exchangers, like scraped surface heat exchangers, moving vessels, and stirred tank reactors. The heat transfer within the recuperator bulkhead is usually administered by conduction. During a heat pipe device, however, the heat pipe not only acts as a bulkhead but also facilitates heat transfer through condensation, evaporation, and conduction of the working fluid within the heat pipe. . Generally, if liquids aren't miscible, the bulkhead are often removed and therefore the interface between the liquids replaces a heat transfer surface such as during a direct contact device.

## II. LITERATURE REVIEW

C. A. Zuritz [1] In this article, the scientific conditions for a three-pipe heat exchanger are created. A contextual investigation is introduced and the figuring technique is examined. The outcomes acquired with the rearranged complete speed of the heat trade condition were in brilliant concurrence with those got with the explanatory conditions. Reenactments show that making an annular zone inside the inward cylinder builds the general heat move productivity and diminishes the heat exchanger length necessity by almost 25%.

Abdalla Gomaa et al. [2] The purpose of this article is to evaluate the performance of the three-tube heat exchanger with finned inserts. The results showed that the introduction of fins into the fluid flow of the inner ring of the three-tube heat exchanger produced a significant improvement in convection heat transfer. A higher performance index is obtained with a greater slope of the rib and a lower height of the rib. Based on the data obtained, numerous empirical expressions were predicted with dimensionless design parameters.

Nawaf Saeid et al. [3] Study of the calorific value of parallel flow heat exchangers in current and countercurrent. The results show that the efficiency of the three-fluid heat exchanger for fixed values of the relevant parameters is always higher than that of the conventional two-fluid heat exchanger. The results also show that with fixed values of the relevant parameters the efficiency of the counter-current is higher than with the three-fluid heat exchangers with parallel current. Limitations / implications of the research - One-dimensional control equations are derived according to the principle of energy saving.

Ahmet Ünal [4] In this investigation, shut structure articulations are determined for NTU effectiveness connections for concentric triple rounded heat exchangers that incorporate both counter-current and equal stream courses of action. Also, some agent information for the two kinds of stream plans are introduced in graphical structure.

### III. OBJECTIVE

In most practical applications of enhancement techniques, the following performance objectives, along with a set of operating constraints and conditions, are usually considered for optimizing the use of a heat exchanger.

1. To observe the effectiveness of parallel flow arrangement of the triple tube heat exchanger.
2. To analyze the heat transfer rate at different values of Reynolds number in a parallel flow heat exchanger.
3. Compare the experimental results of Reynolds number, Nusselt number, friction factor of triple tube heat exchanger in parallel flow arrangement with previous studies.

### IV. METHODOLOGY

Heat exchangers are devices that facilitate the exchange of heat between two liquids at different temperatures, preventing them from mixing. In practice, heat exchangers are widely utilized in a good sort of applications, from heating and air con in homes to chemical processing and power generation in large installations. Heat exchangers differ from mixing chambers therein they are doing not allow mixing of the 2 liquids involved for instance, during a car radiator, heat is transferred from the recent water flowing through the radiator tubes to the air flowing through narrow, narrow plates attached to the surface of the tubes.

Heat transfer during a device generally involves convection in each fluid and conduction through the wall that separates the 2 fluids. When analyzing heat exchangers, it's useful to figure with an overall heat transfer coefficient  $U$  that takes under consideration the contribution of of these effects to heat transfer. The speed of heat transfer between two liquids in one location during a device depends on the dimensions of the temperature difference at that location, which varies along the heat exchanger. When analyzing heat exchangers, it's generally useful to figure with the logarithmic mean temperature difference LMTD, which represents the same mean temperature difference between the 2 liquids for the whole device.

### Assumptions

1. The heat exchanger is well insulated from the environment and therefore the total heat loss of the hot water is equal to the sum of the heat gained from cold water and normal water, and the heat loss from the environment is negligible.
2. Thermal conduction in pipes along the axial direction is negligible.
3. The variations of the kinetic energy and the potential energy of liquid flows are negligible.
4. The properties of the liquid remain constant and there is no pollution.
5. The operating conditions are stable and the total heat transfer coefficient remains constant.

The main objective of this work is the study of the cooling properties of the intermediate pipe through which hot water flows. The basic equations used to describe the thermal fluid properties of the three-pipe heat exchanger are summarized as follows:

$\dot{Q}_h$  = Heat transfer of hot water in KJ/s

$\dot{Q}_c$  = Heat transfer of cold water in KJ/s

$\dot{Q}_n$  = Heat transfer of normal water in KJ/s

$\dot{m}_h$  = Mass flow rate of hot water in Kg/s

$\dot{m}_c$  = Mass flow rate of cold water in Kg/s

$\dot{m}_n$  = Mass flow rate of normal water in Kg/s

$t_{hi}$  = Temperature of hot water at inlet in °C

$t_{ci}$  = Temperature of cold water at inlet in °C

$t_{ni}$  = Temperature of normal water at inlet in °C

$t_{ho}$  = Temperature of hot water at outlet in °C

$t_{co}$  = Temperature of cold water at outlet in °C

$t_{no}$  = Temperature of normal water at outlet in °C

$C_h$  = Specific heat capacity of hot water in KJ/Kg K

$C_c$  = Specific heat capacity of cold water in KJ/Kg K

$C_n$  = Specific heat capacity of normal water in KJ/Kg K

The heat transfer of hot water flowing through intermediate pipe is calculated as

$$\dot{Q}_h = \dot{m}_h C_h (t_{hi} - t_{ho})$$

The heat transfer to cold water flowing through inner pipe is calculated as

$$\dot{Q}_c = \dot{m}_c C_c (t_{co} - t_{ci})$$

The heat transfer to normal water flowing through outer pipe is calculated as

$$\dot{Q}_n = \dot{m}_n C_n (t_{no} - t_{ni})$$

The heat balance between chilled water, normal water and hot water for the triple pipe presupposes the definition and determination of the transferred heat flow and the received heat flows:

$$\dot{Q}_h = \dot{Q}_c + \dot{Q}_n + \dot{Q}_{loss}$$

Since the triple tube heat exchanger is well insulated thermally from the surrounding, therefore

$$\dot{Q}_{loss} = 0$$

And hence

$$\dot{Q}_h = \dot{Q}_c + \dot{Q}_n$$

The Reynolds number is calculated as follows

$$Re = \frac{\rho v D_{hy}}{\mu}$$

Where  $\rho$  = Density of water in Kg/m<sup>3</sup>

$v$  = velocity of water in m/s

$\mu$  = Dynamic viscosity of water in Ns/m<sup>2</sup>

$D_{hy}$  = Hydraulic diameter in m

Hydraulic diameter is calculated as

$$D_{hy} = 4 \cdot \frac{\text{Cross section area}}{\text{Wetted perimeter}} = \frac{\pi}{4} \frac{(D_{out}^2 - D_{in}^2)}{\pi(D_{out} + D_{in})}$$

$$D_{hy} = (D_{out} - D_{in})$$

The Nusselt number for the intermediate pipe is calculated as

$$Nu = \frac{hD_{hy}}{k} = 0.023Re^{0.8}Pr^{1/3}$$

Where  $h$  = Heat transfer coefficient of water in W/m<sup>2</sup>°C

$k$  = Heat transfer coefficient of pipe material in W/m<sup>2</sup>°C

$Pr$  = Prandtl Number

The expression used to calculate pressure drop is

$$\Delta p = 4f \frac{L}{D} \rho \frac{\mu^2}{2}$$

Where 'f' is friction factor which depends upon the roughness of tube material

$$f = 0.00014 + \frac{0.125}{Re^{0.32}}$$

The inlet speed of cold water and normal water is kept at a constant value around 4 l / m, and the speed of hot water has been gradually increased to study the variation of heat transfer to the flow of hot water gradually increases.

The cross section area of inner tube, intermediate tube and the outer tube are  $2.86 \times 10^{-4}$  m<sup>2</sup>,  $1.53 \times 10^{-4}$  m<sup>2</sup> and  $2.01 \times 10^{-4}$  m<sup>2</sup> respectively. The flow rate in m<sup>3</sup> / s, divided by the section of the respective pipe, gives the speed of the water in m / s. Reynolds flux number was determined using velocity. Example of calculating the Reynolds number of hot water at the outlet passing through the intermediate pipe, when discharge was kept at  $7.75 \times 10^{-5}$  m<sup>3</sup>/s, is shown below:

$$v = \frac{7.75 \times 10^{-5}}{1.53 \times 10^{-4}} = 0.05045 \text{ m/s}$$

$$Re = \frac{1000 \times 0.05045 \times 0.02575}{0.686 \times 10^{-3}} = 1894$$

The dynamic viscosity value varies as the water temperature varies. After several experiments and the calculation of the Reynolds number values for different values of a gradually increasing flow, the Nusslet number was calculated. Below is the example of calculating the Nusselt number:

$$Nu = 0.023 \times (1894)^{0.8} \times (4.575)^{1/3} = 15.906$$

The values of the Prandtl number vary as the water temperature changes. The friction factor calculation was performed at different Reynolds number values and one of the example calculations is shown below:

$$f = 0.00014 + \frac{0.125}{(1894)^{0.32}} = 1.25 \times 10^{-2}$$

## V. EXPERIMENTAL SETUP OF HEAT EXCHANGER USED

The experimental study has been conducted on a Triple Tube Heat Exchanger (TTHE) consisting of three concentric pipes, the inner pipe, the intermediate pipe and the outer pipe made of carbon steel having following dimensions:

ID of inner pipe = 19.05 mm

OD of inner pipe = 25.05 mm

ID of intermediate pipe = 50.8 mm

OD of intermediate pipe = 56.8 mm

ID of outer pipe = 76.2 mm

OD of outer pipe = 82.2 mm

Length of the heat exchanger or Heat Transfer length = 3.225 m



Fig. 1: Arrangement of baffles over the pipe.

Room temperature water, i.e. H. Normal water was flowed through the outer tube, cold water was flowed through the inner tube, and hot water circulated through the inner ring. To study the speed of heat transfer by creating an obstacle in the path of the liquid, the fins were inserted into the intermediate tube in the form of rectangular bands. The ribs were made of carbon steel and had a constant height of 10 mm and a thickness of 2 mm. The ribs are inclined at a 90 ° angle above the tube as shown in Fig. 1. Constant fin spacing of 76.2mm was maintained along the length of the tube.



Fig.2: Arrangement of ribs over the pipe.

## Setup and Arrangement

The bladder has been inserted into the intermediate tube, on which there are ribs. This assembly was reinserted into the outer tube to complete the three tube heat exchanger assembly. To hold the three tubes in place, e.g. H. In order to maintain a gap between them, a flange has been welded at both ends of the above arrangement and suitable cutouts have been made on these flanges to direct water of different temperatures through various pipes. Another flange was made with three main holes, and on these holes the 90 ° elbows and the straight pipe were welded to meet the arrangement for the water inlet and outlet, as shown in the figure. 3. Two of these flanges are designed to be attached to both ends of the three-pipe heat exchanger. These flanges were connected to the pipe flanges using a nut and bolt as shown in Fig. 4.



Fig.3: Arrangement of the flange with pipe of heat exchanger



Fig.4: Arrangement of elbows and straight pipe on outer flange

PVC pipes were attached to all water outlets and inlets to bring water from the various tanks to the three pipe heat exchanger. The temperature sensor was also mounted on the PVC pipes by making a hole large enough to insert a temperature sensor to measure the temperature of the hot, normal and cold water at the inlet and outlet. The schematic arrangement of the three-pipe heat exchanger with the other components is shown in Fig.

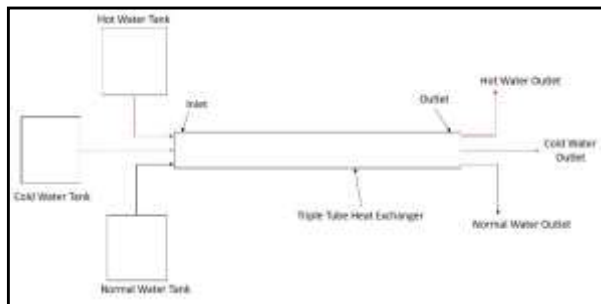

Fig.5: Schematic representation of the setup

Readings of various parameters were made to calculate the values of different quantities such as Reynolds number, Nusselt number, etc., which are mentioned in the next chapter of this work. With this in mind, the experiments were conducted by maintaining a constant height of the water tank to obtain a constant discharge value with an error of about 5%. The incoming hot water temperature was kept at 45 ° C, the incoming cold water temperature was kept at 18 ° C and the normal water temperature was kept between 27 ° C and 28 ° C.

A series of experiments were carried out to study the phenomenon of heat transfer through a three-tube heat

exchanger and a comparison of heat transfer in parallel flow with that in countercurrent was made. The readings were made by varying the outlet flow rate of the incoming water flow rate of the hot water while keeping the incoming cold water and normal water output constant.

The purpose of the fins is to create an obstruction in the water flow that breaks the laminar characteristic of the flow and tries to make it more turbulent, resulting in greater mixing and therefore greater heat transfer from one fluid to another, judged true, forms the reading scheme obtained by modifying the flow parameters and using them in analytical calculations.

Temperature readings are recorded after the temperature sensor output has stabilized for a few minutes. This was observed during the first measurements to get an idea of the stability behavior of the system and the procedure was repeated for other measurements. The temperatures of three water streams are measured using temperature sensors connected to a display to obtain digital readings of the temperatures at the inlet and outlet of the water streams. The readings of T1, T2 and T3 indicate the temperatures of the inlet hot, cold and normal water, and the corresponding outlet values are given respectively by the reading of T4, T5 and T6.

VI. RESULT AND DISCUSSION

In the present work, experiments were carried out to understand the functionality of the three-tube heat exchanger and also the variation in temperature at the inlet and outlet of the heat exchanger. Attempts have been made to keep errors as small as possible and within acceptable limits. The analysis was conducted by examining the behavior of changing the Nusselt number by gradually increasing the Reynolds number of hot water. The same was shown in the table and shown in the graphs below.

S. No	Reynolds Number	Nusselt Number
1	1938.19	15.384
2	2703.301	20.075
3	3612.45	25.316
4	3908.73	26.963
5	4172.41	28.404
6	4871.37	32.1564
7	5498.54	35.428

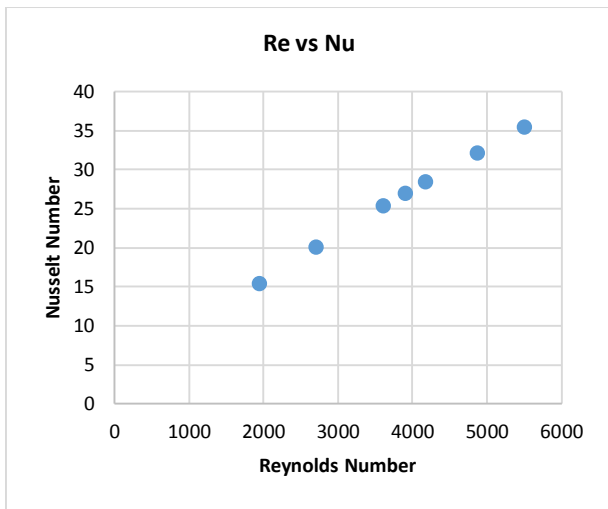

Fig.6: Variation of Reynolds number and Nusselt number

In Fig. 5, it can be seen that the value of the Nusselt number increases as the value of the Reynolds number increases. As the flow becomes inherently turbulent and the turbulence in the flow increases, convective heat transfer becomes dominant over conduction heat transfer.

Another important parameter is the friction factor with which the three-pipe heat exchanger can be analyzed. The study was conducted by gradually increasing the mass flow of hot water and calculating the friction factor with respect to different values of the Reynolds number obtained by varying the mass flow. The same was shown with the help of tables and graphs.

S. No	Reynolds Number	Friction Factor $\times 10^{-2}$
1	1938.19	1.25
2	2703.301	1.14
3	3612.45	1.05
4	3908.73	1.03
5	4172.41	1.01
6	4871.37	0.96
7	5498.54	0.93

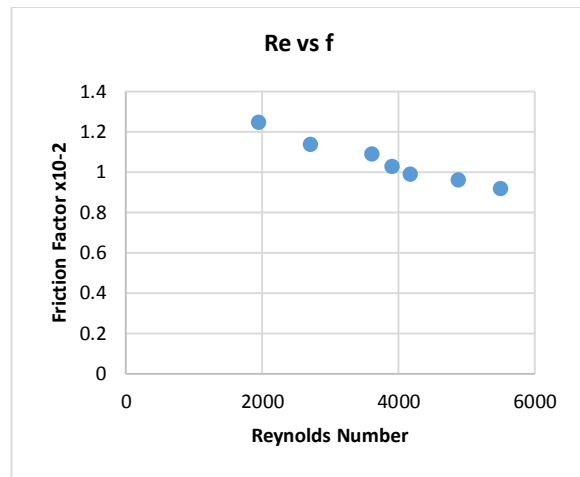

Fig.7: Variation of Reynolds number with friction factor.

In Figure 7, it can be seen that as the Reynolds number increases, the friction factor decreases and the friction factor decreases. This type of variation implies that as the turbulence in the flow increases, the variation in the pressure drop also increases if the diameter and length of the pipe are constant and the density and dynamic viscosity of the fluid can be increased, which leads to an increased friction factor.

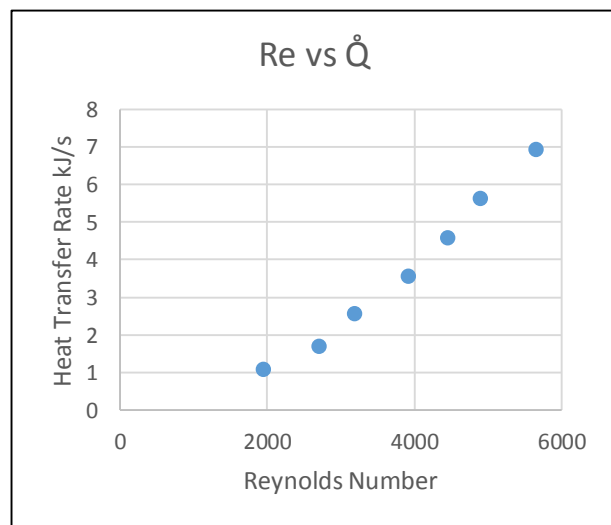

Fig.8: Reynolds number variation with rate of heat transfer

The rate of heat transfer is also getting increased by increasing the Reynolds number of hot fluid. The same can be seen from the Fig.8.

### VII. VALIDATION

The current study was compared with the study by Gomaa et al. [1] and the trend of the graph for Reynolds number versus friction factor and Reynolds number versus Nusselt number were similar [1]. We can therefore say that the current study is validated.

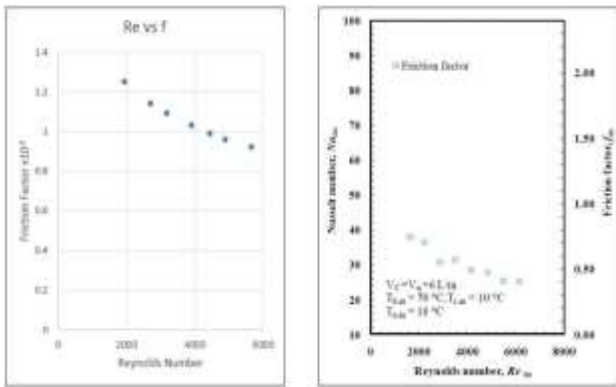

Fig.9: Comparison between current study with base paper of Re vs f

The reason for this variation of the friction factor with the Reynolds number is that the friction factor inversely changes the relationship between them and therefore as the value increases the other decreases, as can be seen in Figure 9 for the two studies in progress.

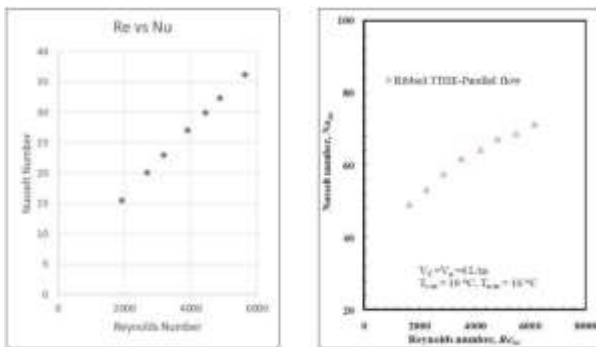

Fig.10: Comparison between current studies with base paper of Re vs Nu

The increase in value of Reynolds number leads to increase in value of Nusselt number because as Reynolds number increases the heat transfer due to convection also gets increased, which can be seen in both in current study and Goma's [1] study as shown in Fig.10

VIII. CONCLUSION

In the work in progress, experiments were performed on a three-tube heat exchanger with spiral baffles which were used to create the obstacle in the fluid path to create turbulence in the flow through the exchanger. After running a series of experiments, calculations were made to give the velocity (v), Reynolds number (Re) of the flow, friction factor (f) and associated Nusselt number (Nu) based on velocity distribution of the fluid to be determined. The following conclusions can be drawn:

- a. As the flow rate increased, the mass flow rate of the liquid increased and the Nusselt number (Nu) associated with the flow rate also increased from 15.38 to 35.42.
- b. It has been observed that the value of the friction factor (f) of the flow decreases from 0.0125 to 0.00934 as the flow velocity increases.

- c. The heat transfer rate ( $\dot{Q}$ ) has been found to increase from 0.636 to 7.712 kJ / s as the Reynolds number (Re) associated with the flow rate increases.

The conclusion that can be drawn from the study is that as fluid flow increases, mass flow rate increases, thereby increasing fluid velocity, resulting in an increase in the Reynolds number. As the Reynolds number increases, turbulence in the flow increases, causing the liquid to mix. The higher the mixing speed, the higher the value of the heat transfer due to convection.

IX. FUTURE SCOPE

The other research that can be done on the same experimental setup is to calculate the heat transfer rate at different values of the hot water inlet temperature and compare the efficiency of the system. The same experimental setup can be used to evaluate the data from the counter-current arrangement and compare it to the present study. A similar structure can be designed with different values for impact height, impact thickness and impact split, and a comparative study can be performed for the optimal impact surface size.

REFERENCE

- [1]Gomaa A, Halim M, Alsaied A. Enhancement of cooling characteristics and optimization of a triple concentric-tube heat exchanger with inserted baffles. International Journal To Thermal Science 2017;120:106-120
- [2] Mazaheri N, Bahiraei M “Analyzing performance of a baffled triple-tube heat exchanger operated with graphene nanoplatelets nanofluid based on entropy generation and exergy destruction” International Communications in Heat and Mass Transfer 2019; 107:55-67.
- [3] Bahiraei M, Mazaheri N. Application of a hybrid nanofluid containing graphene nanoplatelet–platinum composite powder in a triple-tube heat exchanger equipped with inserted baffles. Applied Thermal Science 2019; 149:588-601.
- [4] Amanuel T, Mishra M. Investigation of thermohydraulic performance of triple concentric- tube heat exchanger with CuO/water nanofluid: Numerical approach. Heat transfer Asian research 2018; 47: 974-995.
- [5] Touatit A, Bougriou C. Optimal diameters of triple concentric-tube heat exchangers. International Journal of Heat and Technology 2018; 36: 367-375.
- [6] Shahril S, Quadir G. Thermo hydraulic performance analysis of a shell-and-double concentric tube heat exchanger using CFD. International Journal Of Heat And Mass Transfer 2017; 105: 781-798.
- [7] Wen J, Gu X. Multi-parameter Optimization of Shell-and-Tube Heat Exchanger with Helical Baffles Based on Entropy Theory. Applied Thermal Science 2018;130: 804-813

- [8] Wang S, Xiao J. Application of Response Surface Method and Multi-objective Genetic Algorithm to Configuration Optimization of Shell-and-tube Heat Exchanger with Fold Helical Baffles. *Journal Of Applied Thermal Engineering* 2018; 129: 512-520.