

# Differential Evolutionary and PI Regulated Converter Technology for Loading Analysis in Renewable Energy Systems

Divyanshi Yadav  
M. Tech Scholar

Lakshmi Narain College of Technology Excellence  
Bhopal (M.P), India  
riya29yadav@gmail.com

Prakhar Bhadoria  
Professor

Lakshmi Narain College of Technology Excellence  
Bhopal (M.P), India  
prakharb@lncet.ac.in

**Abstract:** Many remote communities around the world cannot be physically or economically connected to an electrical grid. The main objective of the study of designing an inverter control that attains a lower distortion level in the voltage as well as current waveforms by incorporating an optimization algorithm. The controller should reduce the spikes at the transient loading point when the system is subjected to sudden load changes at the power generating units. And the system is to be integrated with the fuel system also to obtain energy efficiency. The fuel system would be connected in parallel to the DC voltage output of the solar/wind hybrid system. The final hybrid system with fuel cell integration was studied for the total harmonic distortion in the voltage and current waveform. The distortion level in the voltage waveform was found to be 0.25% and that in the current waveform was 1.84%. It is under the IEEE acceptable limits.

**Keywords:** DC, AC, THD, hybrid system.

## I. INTRODUCTION

Many remote communities around the world cannot be physically or economically connected to an electrical grid. Electricity demand in these regions has traditionally been met by small isolated diesel generators. The operating costs associated with these diesel generators can be too high due to the reduction in fossil fuel costs and the difficulty of powering and maintaining the generators. In such situations, renewable energy sources such as solar photovoltaic (PV) and wind turbines offer a realistic alternative to integrate motor generators for power generation in off-grid areas. Hybrid power systems have been shown to significantly reduce the total lifecycle cost of off-grid power supplies in many off-grid situations, while ensuring reliable power with a combination of power sources. Many hybrid systems have been installed around the world, and the expanding renewable energy industry has now developed reliable and cost-effective systems using a variety of technologies.

This implies a huge potential for energy production which, with current renewable energy technologies, can reach several hundred GW. As the cost of building solar PV wind capacity will continue to decline over the next five to ten years; a significant expansion of renewable energy is a very realistic possibility in developing countries. Thousands of villages around the world are still disconnected from the electricity grid and powering these villages from extended grids or diesel generators alone will be inefficient. Furthermore, given the current scarcity of resources, these villages are given a low priority for network expansion with the government due to the low potential economic return. Independent solar-photovoltaic-wind hybrid energy systems can supply electricity to these local needs in an economical and reliable way. Solar and wind energy are inexhaustible sources, depending on the location, environmentally friendly and possible alternative energy sources.

## II. LITERATURE REVIEW

B. Venkatasamy et al. [1] this article fixes the average life span of a wind turbine at between 20 and 25 years, electricity is also produced in wind turbines after the average life. However, if the wind turbine is used after this average life, the maximum power that can be generated is reduced due to the aging of the mechanical parts and maintenance factors. Other devices such as the transformer and switchgear can also operate with a reasonable degree of efficiency once the wind turbine has reached its maximum life. Therefore, the use of a wind turbine can be improved by connecting a solar system to the existing group of transformers and panels, which forms a hybrid wind-solar system.

K. Arulkumar et al. [2] In recent years, a photovoltaic system connected to the grid has emerged in its simplicity, reliability and insurability. Grid inverter ranges are classified into small tens of kilowatts, and large ones into hundreds of megawatts.

As a result, the grid connection standard has increased, improving the reliability, efficiency and costs of the electricity grid. Furthermore, the functionality of a grid connected inverter depends primarily on the robustness of the control strategy, even with abnormal grid conditions such as voltage and frequency deviations.

Soo-Bin Kim et al. [3] this article presents the high penetration of decentralized generators such as solar and wind generators in low voltage grids, which cause problems with increasing voltage. Controlling the reactive power of distributed generators can help reduce voltage rise. With the existing reactive power control, the reactive power was only adjusted with a local variable, e.g. B. the voltage at the connection point or the active output power of the distributed generator.

Rashid Al Badwawi et al. [4] This article provides an overview of the challenges and opportunities / solutions of hybrid solar photovoltaic and wind energy integration systems. Voltage and frequency fluctuations as well as harmonics are major power quality problems for grid-connected and stand-alone systems, which have a major impact on weak grids. Much of this can be solved with proper design, advanced rapid response control capabilities, and proper optimization of hybrid systems.

III. OBJECTIVE

The work proposes to attain following key objectives from the research:

- Designing of a grid integrated solar wind hybrid energy system for driving loads for improving its reliability and efficiency.
- Designing an inverter control that attains lower distortion level in the voltage as well as current waveforms by incorporating optimization algorithm. The controller should reduce the spikes at the transient loading point when the system is subjected to sudden load changes at the power generating units.
- The system is to be integrated with the fuel system also to obtain the energy efficiency. The fuel system would be connected in parallel to the DC voltage output of the solar/wind hybrid system.
- Improvement in the reactive power output from the system by the inverter control by designed hybrid system that can compensate the reactive power requirement when required.
- This project should attain the hybrid solar/wind/fuel system with proposed controller to improve the output parameters.

IV. MODELING COMPONENTS

A. Modeling of hybrid system

Various modeling techniques are developed by researchers to model components of HRES. Performance of individual component is either modeled by deterministic or probabilistic approaches. This chapter discusses the basic modeling structures of solar energy system, and Wind energy system along with modeling of PSS controls.

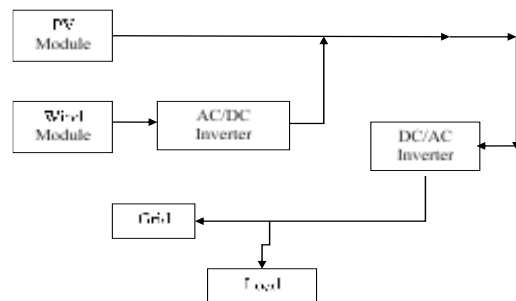

Fig. 1 Proposed Hybrid energy system topology

Table 1 PV module Parameters

Model	1Soltech 1STH
Maximum Power	213.5 Watts
Number of parallel strings	40
Number series modules	10
Open circuit voltage	36.3 Volts
Shot circuit current	7.84 Ampere
Irradiation	1000 wb/m <sup>2</sup>
Temperature	30°C

Table 2 Wind energy system parameters

Wind speed	11 m/sec
Number of wind turbines	80
Nominal power	2 MW
Frequency	50 hertz
Line to line voltage	410 V
Friction factor	0.01
Number of poles	1
Inertia constant	0.62

B. Controller designing

The inverter control designing has been done so as to improve the system parameters. The designing has been done in dq0 reference frame to ease the study of the elemental parts and their respective changes. The system continuously keeps a check on the variable parameters and updates as per the requirement.

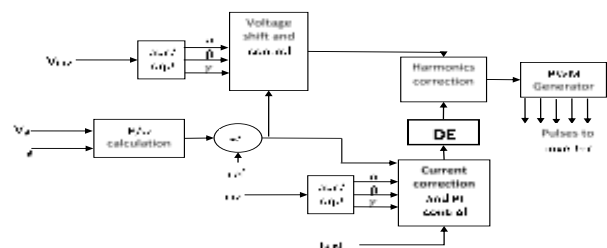

Fig.2 differential evolutionary (DE) optimization and hysteresis band integrated PI controller for inverter

The above controller provides pulses to the inverter which is a three leg 6 pulse inverter. The controller takes grid parameters, load parameters and inverter output parameters as inputs. The active power and reactive power requirement has been checked and is meant to be improved as per the changes. The current reference control plays a crucial role in regulating the reactive power by adjusting phase as well as load requirement by adjusting the gain parameter of the PI control. The output from the PI controller is regulated by proposed differential evolutionary algorithm by performing specific iterations and producing more optimum results. The harmonic correction is done before the signal is sent to the PWM generator for pulse generation. This differential evolutionary (DE) optimization and hysteresis band integrated PI controller for inverter is meant to work and update at each point of the system variation to prove a better pulse so as to yield an enhanced output parameters. The DE optimizing algorithm coding and performance is carried out in the following steps as shown in flow chart below:

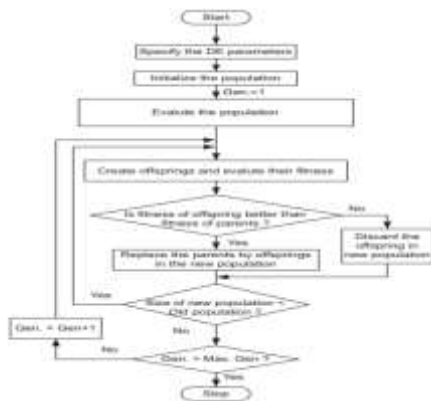

Fig. 3 Flow chart of proposed Differential Evolutionary Algorithm for converters

Differential Evolution (DE) is a population-based heuristic algorithm to solve global optimization problems with different characteristics over continuous space. Despite its simplicity, it proved a great performance in solving non-differentiable, non-continuous and multi-modal optimization problems. In simple DE, DE/rand/1/bin, an initial population of NP individuals  $\bar{X}_j$ ,  $j=1, 2, \dots, NP$ , is generated at random according to a uniform distribution within lower and upper boundaries ( $x_j^l, x_j^u$ ). Individuals are evolved by the means of crossover and mutation to generate a trial vector. The trial vector competes with his parent in order to select the fittest to the next generation. The steps of DE are:

a) Initialization of a population

Initial population in DE, as the starting point for the process of optimization, is created by assigning a random chosen value for each decision variable in every vector, as indicated in equation:

$$x_{ij}^0 = L_j + rand_j * (U_j - L_j)$$

Where  $L_j, U_j$ , are the lower and upper boundaries for  $x_{ij}$   $rand_j$  random number uniform [0, 1].

b) Mutation

A mutant vector  $V_i^{G+1}$  is generated for each target vector  $x_i^G$  at generation G according to equation (2)

$$V_i^{G+1} = x_{r_1}^G + F * (x_{r_2}^G - x_{r_3}^G), r_1 \neq r_2 \neq r_3 \neq i$$

Where  $r_1, r_2, r_3$  are randomly chosen from the population. The mutation factor  $F \in [0, 2]$ . A new value for the component of mutant vector is generated using (1) if it violates the boundary constraints.

c) Recombination (crossover)

Crossover is the process of swapping information between the target and the mutated individuals using (3), to yield the trial vector  $u_i^{G+1}$

$$u_{ij}^{G+1} = \begin{cases} v_{ij}^{G+1}, \text{rand}(j) \leq CR \text{ or } j = \text{rand}(i), \\ x_{ij}^G, \text{rand}(j) > CR \text{ and } j \neq \text{rand}(i), \end{cases}$$

V. WORK DESCRIPTION

The work first was focused on making a hybrid solar wind energy system connected to the grid. The solar system specifications as mentioned in the previous chapter were taken for analysis. The system is made to drive different loads switching at different times. The voltage and current output in the 30Kwatt load line as according to the paper has been shown below. The fig.4 and fig.5 shows the voltage and current output at the line where the load is connected and power is being fed to them.

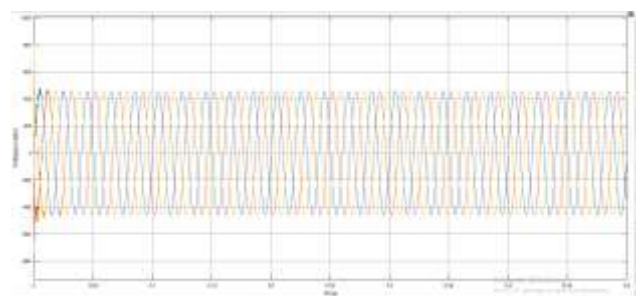

Fig. 4 Voltage at the load line

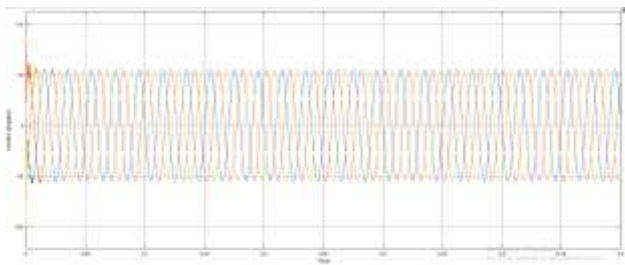

Fig. 5 Current at the load line

The operating line voltage for the load interconnection is maintained to be 500 volts. The system is made to drive another 30 KW load from the system connected in parallel. The above analysis was carried out with the basic voltage regulatory control for the inverter. In order to study the effect of our proposed controller, the same system was subjected to the proposed differential evolutionary (DE) optimization and hysteresis band integrated PI controller for inverter and its effect on the current and voltage waveforms at the load terminal was analyzed. The distortion level in the current and voltage waveforms were studied and were found to be as follows.

Parameters	System with voltage regulation control	System with proposed controller
THD% in voltage	0.78%	0.12 %
THD% in current	2.61 %	0.56 %

It was concluded that by using the designed controller in the hybrid solar wind energy system the distortion level in the voltage and current waveforms was significantly reduced. This proves the efficiency of the designed controller as a total harmonic level reducer in the circuit and thereby making is more reluctant. Further the analysis was carried forward to transient loading conditions when a load was suddenly switched on into the line at 0.2 seconds of simulation time.

A. Load analysis

For this analysis the changes in the current waveform was analyzed at the interval when the load was switched into the lined suddenly. For this purpose three phase line breaker was used along with the 30KW load whose initial state remains at off condition. At 0.2 seconds the breaker switches its state to on and the load gets connected to the line. The line voltage remains the same tat is 500 volts. The changes in the current waveform were studied by analyzing the THD level in current waveform due to sudden loading of line at 0.2 seconds when the load is switched into the line.

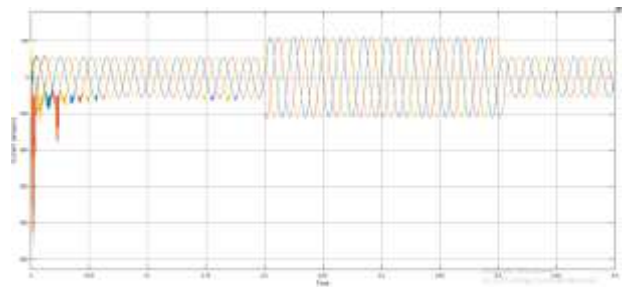

Fig. 6 Current drawn from the load terminal with voltage error regulation control

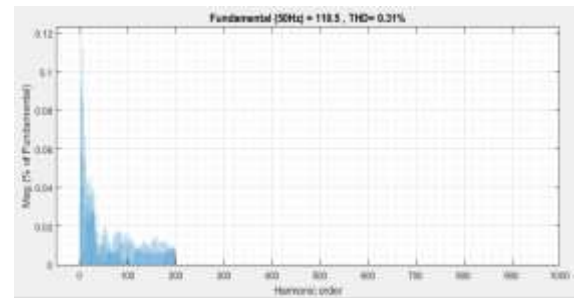

Fig. 7 THD% in Current drawn from the load terminal with voltage error regulation control at transient loading

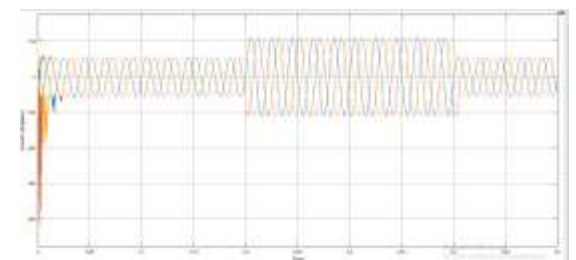

Fig. 8 Current at the load terminal with proposed DE approach for multi objective quality enhancement control of inverter

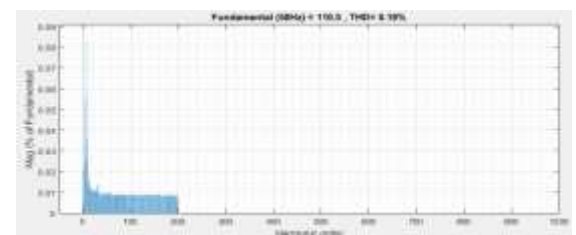

Fig. 9 THD% in Current at the load terminal at time of transient loading with proposed controller

Looking at the current waveforms the switching of 30KW load is done in the load line. The effectiveness of the controller with differential evolutionary optimizing algorithm is studied at these points. The three phase breaker is closed from 0.2 to 0.4 seconds and at this time the 30KW load is suddenly switched out from the load line decreasing the amount of current drawn. The effect on the AC current waveform at 0.4 seconds where off loading takes place is studied.

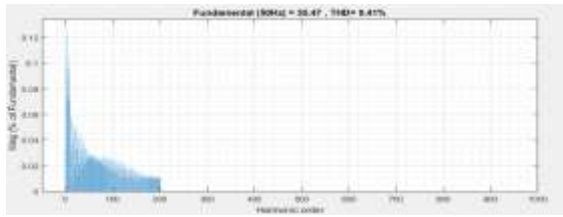

Fig. 10 THD% of Current drawn from the load terminal with voltage error regulation control at transient loading

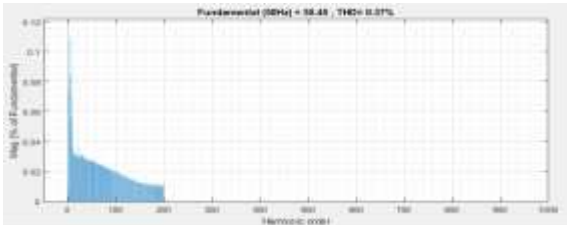

Fig. 11 THD% of Current at the load terminal at time of transient off loading with proposed controller

Form the above figures it can be concluded that the distortion level in the current drawn at the load terminal at the transient loading at 0.2 seconds has reduced as well as at the time of transient off loading. The changes in the THD level is from 0.31% in the current waveform with voltage error regulation control to 0.18% with the proposed differential evolutionary (DE) optimization and hysteresis band integrated PI controller for inverter. Also the THD% in current waveform at the time of off loading at 0.4 seconds was reduced from 0.41% with voltage error regulation control to 0.37% with proposed controller. Though the changes in both the system is small the designed controller has proven to be still an effective choice for driving the inverter in the system.

Parameters	System with voltage regulation control	System with proposed controller
During loading at 0.2 sec	0.31%	0.18 %
During off loading at 0.4 sec	0.41 %	0.37 %

**B. Fuel system integration**

The PEMFC is an electrochemical device which allows the electric energy conversion of the chemical energy contained in a reaction between a fuel, the hydrogen, and an oxidizer, the oxygen

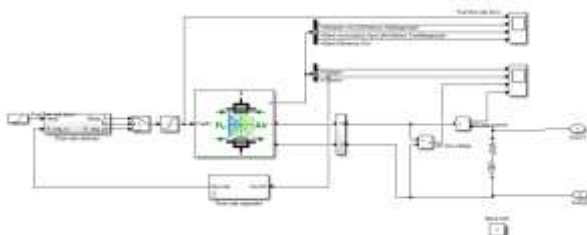

Fig. 12 MATLAB/SIMULINK model of fuel system

A bias voltage is applied across the electrochemical cell in order to induce electrochemical reactions at both electrodes. Water is introduced at the anode and dissociated into oxygen, protons, and electrons. The protons are driven by an electric field through the PEM to the cathode where they combine with the electrons arriving from the external circuit to form hydrogen gas.

Fuel cells are compact, low-noise energy generators that use hydrogen and oxygen to generate electricity. The transport sector is the most important potential market for fuel cells and car manufacturers invest heavily in research and development. However, energy production is seen as a market in which fuel cells can be marketed much faster. Fuel cells can achieve high efficiency (35% -60%) compared to conventional technologies.

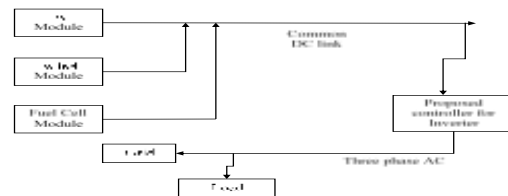

Fig. 13 Connection approach for hybrid solar/wind/fuel cell system

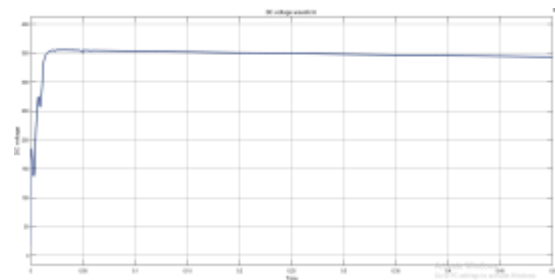

Fig. 14 Common DC link voltage for all the energy resources

The solar/wind/fuel energy system was configured were configured to be connected in parallel having common voltage the fig.depicts the Common DC voltage line through which the three renewable energy resources are being connected it is maintained approximately to be 350 volts.

**C. Boost converter Designing**

The Boost Converter block represents a converter that steps up DC voltage as driven by an attached controller and gate-signal generator. Boost converters are also known as step-up voltage regulators because they increase voltage magnitude.

The Boost Converter block allows you to model an asynchronous converter with one switching device or a synchronous converter with two switching devices like GTO — Gate turn-off Thyristor, IGBT, MOSFET and Thyristors.

The Boost Converter block allows you to model an asynchronous converter with one switching device or a synchronous converter with two switching devices like GTO

— Gate turn-off Thyristor, IGBT, MOSFET and Thyristors. In our work we have used a boost converter that is regulating the DC link voltage and stabilizing it for long run.

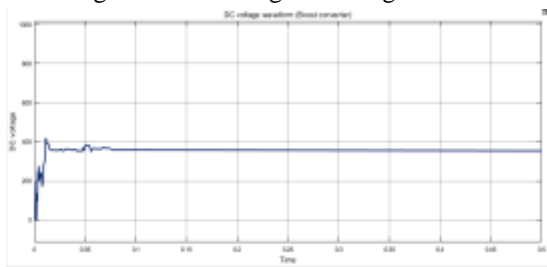

Fig. 15 DC voltage waveform after the boost converter

The fig. shows the DC voltage output from the system after using the DC-DC boost converter. It was found to be improved to approximately 390 volts after boost conversion. This improves the voltage input to the inverter for DC/AC conversion utilizing metaheuristic approach for quality enhancement controller

VI. FINAL SYSTEM RESULT EVALUATION

A Hybrid Power System (HPS) utilizes two or more energy sources, power converters and/or storage devices. The main purpose of HPS is to combine multiple energy sources and/or storage devices which are complement of each other. Thus, higher efficiency can be achieved by taking the advantage of each individual energy source and/or device while overcoming their limitations. In this chapter the analysis of the system having hybrid solar/wind energy system with basic voltage error source control for the inverter is done. It is made to drive the 30KW load at some distance (2km) from the generation. The output from the system is then compared with another system having solar/wind/ fuel cell energy resources in a hybrid form and the inverter is controlled by self designed differential evolutionary (DE) optimization and hysteresis band integrated PI controller for inverter for enhancing all the output parameters as compared to the previous system. THD% is calculated neglecting the transients at the starting of generating stations. This chapter has discussed output from the hybrid system using stabilizer in the following mentioned cases:

CASE 1: Voltage regulation based inverter control for DC output from hybrid solar/wind energy systems

CASE 2: proposed differential evolutionary (DE) optimization and hysteresis band integrated PI controller for inverter in hybrid solar/wind/fuel cell system

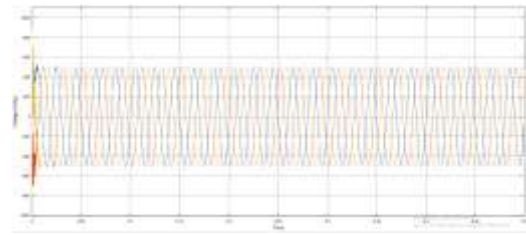

Fig. 16 Voltage output from the solar/wind hybrid system with voltage regulation controlled inverter controller

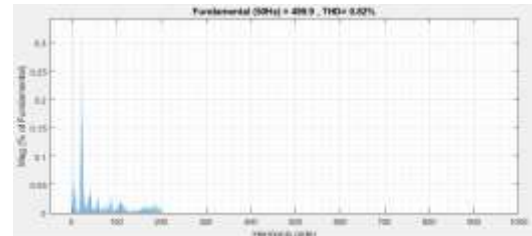

Fig. 17 THD% in voltage output from the solar/wind hybrid system

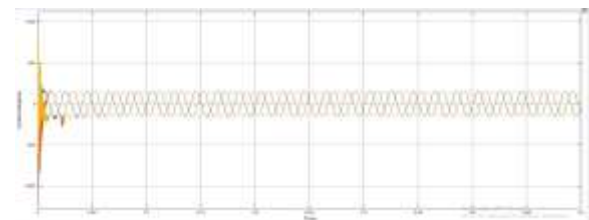

Fig. 18 Current output from the solar/wind hybrid system with voltage regulation controlled inverter controller

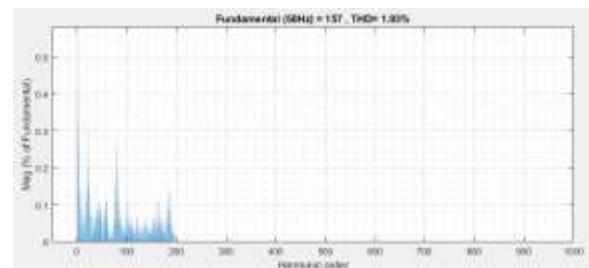

Fig. 19 THD% in Current output from the solar/wind hybrid system



Fig. 20 Active power output from the solar/wind hybrid system with voltage source controller

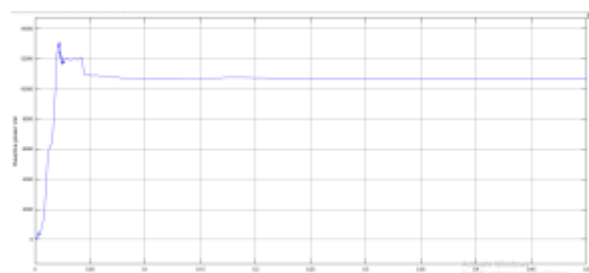

Fig. 21 Reactive power output from the solar/wind hybrid system with voltage source controller

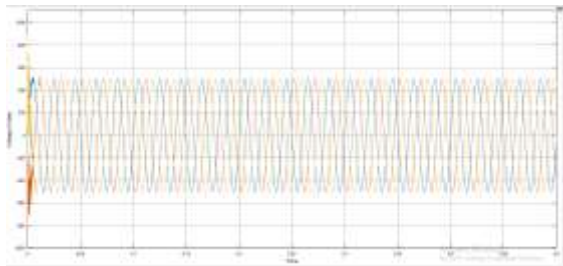

Fig. 22 Voltage output from the hybrid solar/wind/fuel cell system having proposed DE optimization based regulatory controller

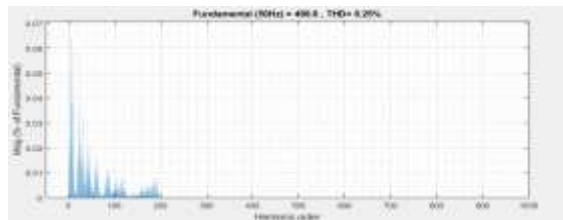

Fig. 23 THD% in Voltage output from the proposed hybrid solar/wind/fuel cell system

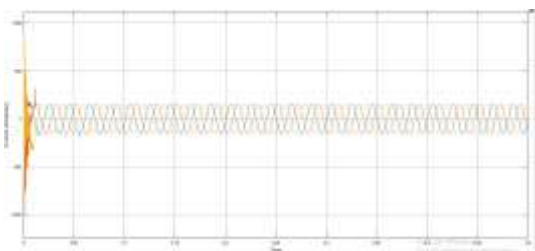

Fig. 24 Current output from the hybrid solar/wind/fuel cell system having proposed DE optimization based regulatory controller

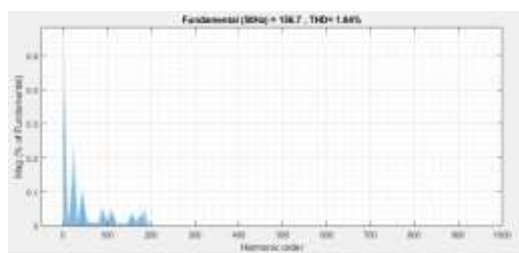

Fig. 25 THD% in current output from the proposed hybrid solar/wind/fuel cell system

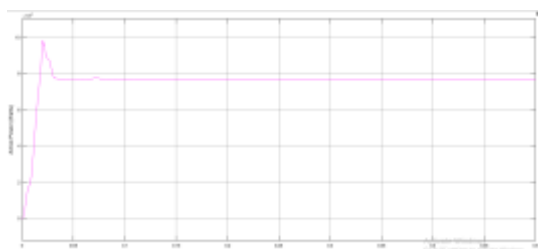

Fig. 26 Active Power output from the hybrid solar/wind/fuel cell system having proposed DE optimization based regulatory controller

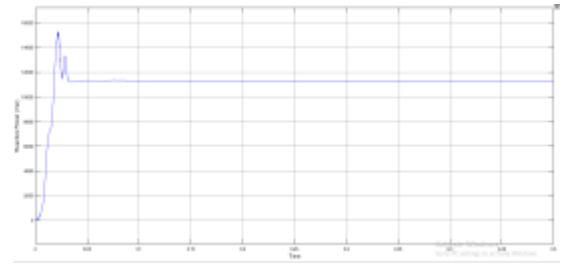

Fig. 27 Reactive power output from the hybrid solar/wind/fuel cell system having proposed DE optimization based regulatory controller

VII. CONCLUSION AND FUTURE SCOPE

A. Conclusion

Renewable energy sources also called non-conventional type of energy are continuously replenished by natural processes. Hybrid systems are the right solution for a clean energy production. Hybridizing solar and wind power sources provide a realistic form of power generation. Here, a hybrid wind solar energy and fuel cell system with a converter topology is proposed which makes use of Boost Converter and proposed differential evolutionary (DE) optimization and hysteresis band integrated PI controller for obtaining quality control through inverter. The operational optimization and power-electronics based voltage–power control was developed, and the functioning was demonstrated through simulation.

Parameters/ Model	Hybrid solar/wind system with voltage regulation control of inverter	Hybrid solar/wind/FC system with proposed DE based controller
Active Power (Watts)	74920	77090
THD% in voltage	0.82%	0.25%
THD% Current	1.93%	1.84%
Reactive Power (Var)	10710	11300
Power Factor	0.95	0.98

$$\begin{aligned} \% \text{ increase in power} &= \left( \frac{\text{New output power} - \text{Old output power}}{\text{old output power}} \right) \times 100 \\ &= [(77090 - 74920) / 74920] \times 100 \\ &= 2.89\% \end{aligned}$$

Power electronics is a key enabling technology in connecting all energy resources to the dc bus. Their control can functionally enhance the output parameters of the hybrid system. The inverter controller was designed keeping in mind the various parameters of the power system and their respective improvement. The following main conclusions were drawn from the work.

- The designed control was first analyzed for harmonic level distortion in the voltage and current output waveforms at the starting when the loads are fed nearby

to the generating point. It was found that the proposed approach has reduced the distortion in voltage as well as current waveform.

- Further the control was analyzed for sudden loading conditions. The distortion in current waveform was studied and it was found to be less in the proposed controller as compared to the voltage source control at both loading as well as off loading points.
- The system reactive power has enhanced that is meant to drive the loads that require reactive power thus reducing the requirement of separate compensating device.
- The active power has also rises in accordance with the increase in input to the inverter to as well as improvement in the power factor of the system hence improving the system efficiency by 2.89%
- The final hybrid system with fuel cell integration was studied for the total harmonic distortion in the voltage and current waveform. The distortion level in the voltage waveform was found to be 0.25% and that in the current waveform was 1.84%. It is under the IEEE acceptable limits.

#### B. Future Scope

Installing this solar-grid hybrid system will be actually very fruitful because it will reduce the grid dependency. On the other hand, this system promotes green energy which is very important because all the energy sources are depleting day by day. So, people must look for new renewable sources and solar power is definitely one of the best choices in this purpose. In future work an adaptive neural network based control for improved power quality 3 phase grid integrated with nonlinear and linear loads will be designed for this system having three sources in the form of solar/wind/fuel cell based hybrid system. The expected control scheme regulates the system voltage and improves the power quality in a very effective manner.

#### REFERENCES

- [1] B.Venkatasamy, Dr.L.Kalaivani "Performance Analysis of Grid-Tie Inverter for Reactive Power Injection Mode in Hybrid Wind Solar Energy System" Proceedings of the 2nd International Conference on Trends in Electronics and Informatics (ICOEI 2018).
- [2] K.Arulkumar, K.Palanisamy "Recent Advances and Control Techniques in Grid Connected Pv System – A Review" international journal of renewable energy research, Vol.6, No.3, 2016
- [3] Soo-Bin Kim, Seung-Ho Song "A Hybrid Reactive Power Control Method of Distributed Generation to Mitigate Voltage Rise in Low-Voltage Grid" Department of Electrical Engineering, Kwangwoon University, Seoul 01897, 21 April 2020
- [4] Sagar Nimkar, Amol Bhagat "Grid Power Quality Improvement on Integration of Wind Energy and PV Solar System using STATCOM" DOI: 10.4028/www.scientific.net/AMM.833.33, April 2016.
- [4] Rashid Al Badwawi, Mohammad Abusara "A Review of Hybrid Solar PV and Wind Energy System" Smart Science Vol. 3, No. 3, pp. 127-138(2015).
- [5] Mohammad Nazmul Islam Sarkar, Lasantha Gunaruwan Meeegahapola "Reactive Power Management in Renewable Rich Power Grids: A Review of Grid-Codes, Renewable Generators, Support Devices, Control Strategies and Optimization Algorithms" Volume 6, 2018.
- [6] B. Kavya Santhoshi, Mohan a sundaram Kuppusamy "A Critical Review on PV Grid -Tied Inverters" DOI: 10.3390/en12101921, may 2019.
- [7] Ying Liu ; Wenping Qin "Modelling of large-scale wind/solar hybrid system and influence analysis on power system transient voltage stability" DOI: 10.1109/ICIEA.2017.8282892 18-20 June 2017
- [8] Hamdy M. Sultan, Ahmed A. ZakiDiab "Evaluation of the Impact of High Penetration Levels of PV Power Plants on the Capacity, Frequency and Voltage Stability of Egypt's Unified Grid" Published: 11 February 2019
- [9] A Arabali, M Ghofrani, M Etezadi-Amoli et al., "Stochastic performance assessment and sizing for a hybrid power system of Solar/Wind/Energy storage[J]", IEEE Transactions on Sustainable Energy, vol. 5, no. 2, pp. 363-371, 2014.
- [10] S. Wang, G. Tian "Coordination control of wind/PV hybrid system" TaiyangnengXuebao/ActaEnergiae Solaris Sinica 31(5):654-660 May 2010