

Analysis of Resistive Type SFCL for Optimum Performance with Relay using AI Techniques

Vipul Sharma

M. Tech. Scholar

NRI Institute of Research & Technology

Bhopal, India

vipul10511@gmail.com

Ms. Madhu Upadhyay

Head of Department

NRI Institute of Research & Technology

Bhopal, India

madyant44@gmail.com

Abstract: The fault current levels of an interconnected power network have witnessed a general rise due to increase in power demand. In this study are designing of test system comprising of superfluous fault current limiter. This system shall be used to check the different AI based control algorithms on relay operation. The coordination and control of the relay based in accordance with the SFCL operation by using an efficient artificial based technique. To reduce the operating time of SFCL and senses the fault current quickly to overcome its effects. The best proposed algorithm should be implemented in an IEEE 9 bus system comprising of hybrid renewable energy resource. The system is effective and efficient while dealing with the fault situation. The work has done experiments on a test system and studied the effects of SFCL on it by changing the controlling algorithms for fast sensing and mitigation of fault current in the relay circuit.

Keywords: SFCL, DG, SC, Shunt.

I. INTRODUCTION

The requirement of the electricity in the world is increasing at a high rate including India and demand of power is greater than the supply of power due to bigger houses, population growth, air conditioners, bigger TVs and more computers. Up to now, many techniques such as, higher impedance transformer, split bus bars and fuses have been used in many industries to suppress magnitude of the fault currents. However, these devices can affect the reliability of the power system and increase the power loss. SFCL is one of the most recent solutions to the problem of increasing the leakage current [1][2].

The fault current levels of an interconnected electricity network have generally increased due to the increase in energy requirements. This increase in fault current, if not reduced correctly, may exceed the maximum rated value of the switchgear. Many conventional protective devices

such as series reactors, fuses, high resistance transformers, etc. have high costs, increased power loss, and loss of power system stability, which can ultimately lead to reduced reliability and reduced operational flexibility. The superconductive fault current limiter (SFCL) is a flexible alternative to the use of conventional protective devices because it effectively reduces the fault current during the first fault current cycle, the reduced weight and the zero impedance during the normal operation.

Research and development of SFCL are being conduct by several electrical manufacturers, and utility for electric transmission lines. Future installing of SFCL in the transmission network will require the evaluation of their impact on the coordination between generator capability curves and generator distance phase backup protection [6].

II. LITERATURE REVIEW

Alexandre Bitencourt et al. [1] This article presented the increase in demand for electricity and the increase in decentralized production, which led to an increase in the short-circuit current in the substations. This paper offers a technical evaluation of two known topologies of fault current limiters through theoretical analyzes of the technical and operational aspects. Small prototypes are used to better understand these analyzes. The topologies examined are called series switching inductors and resonance circuits. The short-circuit current had a reduction of 69.7% for the switched inductance topology and 72.6% for the resonance topology.

Sankalpa Bohidar et al. [2] In the coming smart grid, among the important issues related to the application of

the “Superconducting Fault Current Limiters” (SFCL) is linked to its potential outcome on the decrease of abnormal fault Current. Because of the increased rate of failure currents, SFCL is most likely to enter a media and low-voltage network to reduce the electrical systems' ability and enhance the strength of the devices. This article first presents a resistive style SFCL model using Matlab / Simulink and then replicates distinct fault kinds and analyzes are performed without SFCL and SFCL. The research demonstrates that SFCL reduces the amount of the fault current to a satisfying stage but also reduces the thermal temporary restoration voltage. SFCL also increases the temporary strength, energy performance and efficiency of energy scheme by spontaneously decreasing error flow.

Ahmed Hatata et al. [3] this study presents a new approach for the implementation of superconducting resistive fault current limiters with DG units in order to obtain an optimal regulation of the protection system. The protection coordination setting is optimized using Particle Swarm Optimization (PSO) technology. The proposed algorithm is tested on a power distribution system with nine bus loops and the effects of SFCL on the protection system of the connected DG network are analyzed. Three cases are examined: no DGs, DGs connected to the network with SFCL and DGs connected to the network without SFCL. Different simulations are implemented for different error positions.

R. Haider et al. [4] the article describes the modeling, characterization and implementation of SFCL to improve the transition stability of the power system. The penetration of decentralized production (DG) by micro-grid systems is constantly increasing in order to cover the growing demand for energy. The energy supplied by the microgrids has increased the overall reliability of the electricity grids, but protection problems have been observed. These problems must be solved for the fuel system to function properly. Superconducting Fault Current Limiters (SFCL) provide the power supply system with unique protection functions under various fault conditions.

III. OBJECTIVE

This thesis will target on the following main objectives:

- Designing of test system comprising of superfluous fault current limiter. This system shall be used to

check the different AI based control algorithms on relay operation.

- The coordination and control of the relay based in accordance with the SFCL operation by using an efficient artificial based technique.
- To reduce the operating time of SFCL and senses the fault current quickly to overcome its effects.
- The best proposed algorithm should be implemented in an IEEE 9 bus system comprising of hybrid renewable energy resource. The system is effective and efficient while dealing with the fault situation.

IV. METHODOLOGY

The increase in the power generation capacity of the power supply systems has led to an increase in the level of fault current, which can exceed the maximum short circuit values of the equipment. Many conventional protective devices installed to protect against excessive residual currents in power systems, particularly in power plants, are circuit breakers activated by an overcurrent protection relay.

The superconducting residual current limiter is an innovative electrical device that can reduce the residual current level during the first residual current cycle. Use of the residual current limiter would not only reduce the load on network devices, but could also provide a connection to improve the reliability of the power system. A superconducting fault current limiter (SFCL) in series with a downstream circuit breaker could be a viable solution for controlling fault current levels in electrical distribution networks. To integrate SFCL into electricity grids, we need a way to easily predict SFCL performance in a particular scenario.

As part of our work, we have also developed a test system in which the SFCL works warmly with an automatic switch and a relay circuit. The various artificial intelligence algorithms are tested to predict the operating time of the circuit breaker and SFCL. This chapter explains the different test methods, then the final installation of the SFCL in an IEEE 9 bus system for the cooperative operation of various relay circuits.

A. Resistive-type SFCL

One type of SFCL resistor directly uses the transition from the superconducting state to the normal state that a superconductive material (SCM) presents when the transport current exceeds the critical value [3].

In practice, it consists of a non-inductive winding consisting of a superconductive wire or strip, connected in parallel to an external shunt, which can be resistive or inductive. The external shunt provides an alternate path to the current during the fault, thus reducing the Joule heating of the superconductor. An external resistive shunt is advantageous from the point of view of the power supply system, since it does not delay the zero crossing of the current and does not reduce the transition stability of the network.

Usually the non-inductive winding consists of a two-wire spiral or some other pancake arrangement. In addition, a ground superconducting tube that has been properly cut on the surface to create a current path similar to that of a two-wire coil can be used to make a resistive SFCL.

To avoid the risk of hot spots, the superconductor must be in contact with a normally conductive matrix (as in the case of BSCCO and MgB2 composite tapes or wires) or a shunt layer (as in the case of conductors coated with YBCO or loose BSCCO Tube). The purpose of the matrix or shunt layer is to promote uniform hardening diffusion; therefore, they have a high thermal and electrical conductivity.

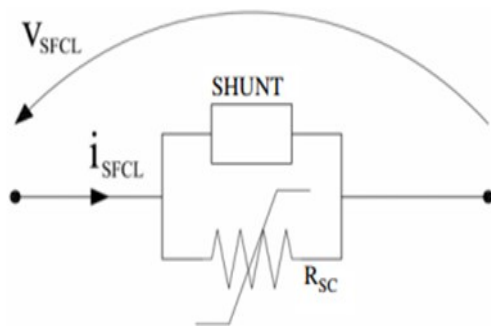

Fig. 1 Circuit scheme of a resistive-type SFCL.

A circuit diagram of one type of SFCL resistance is shown in Fig 1. The non-linear resistance RSC is given by the parallel equivalent of the superconductor and by the normal conductive matrix or shunt layer. The presence of the material with low resistivity allows only a low equivalent resistance value even after the end of the transition.

The only way to obtain an appropriate value for the SFCL resistance is to increase the length of the superconductor. However, this leads to an increase in AC current losses to values not allowed for high voltage applications where a

high enough resistance is required to keep the fault current at an acceptable level.

B. PSO algorithm

Particle swarm optimization PSO is a novel swarm optimization algorithm that is firstly proposed by Kennedy as an evolutionary algorithm based on behavior of birds. PSO uses a set of particles that each one suggests a solution to the optimization problem. It is based on the success of all particles that emulates a population where the position of each particle depends to the agent position to detect the best solution P_{best} by using current particles in the population G . The position of any particle x_i is adjusted by

$$x_i^{k+1} = x_i^k + v_i \quad (1)$$

Where the velocity component v_i represents the step size and is calculated by:

$$v_i^k = wv_i^k + c_1r_1(P_{best_i} - x_i^k) + c_2r_2(G - x_i^k) \quad (2)$$

Where w is the inertial weight, c_1 and c_2 are the acceleration coefficients, r_1 and r_2 are random values that belong to the interval of $[0, 1]$, P_{best_i} is the best position of particle i , and G is the best position in the entire population.

The operation given in flowchart can be analyzed in five steps that are initialization, fitness evaluation, updating the individual and global best value, updating the velocity and position of each particle, and convergence determination. In the first step, particles are randomly initialized in the distribution space, or are initialized on described grid nodes covering the search space.

Similarly, the initial velocity values are defined randomly. The fitness value of each particle is evaluated in the second step where the fitness evaluation is led to provide candidate solution to the objective function. The individual and global best fitness values are determined in the third step where p_{best_i} and g_{best} are respectively determined.

C. ACO algorithm

ACO is a discrete combinatorial optimization algorithm based on the collective behavior of ants in their search for food. An ant colony is said to be able to find the shortest path from its nest to a food source through an indirect form of communication, in which a chemical called pheromone settles along the way. Over time, the shorter and more desirable pathways are integrated with larger quantities of pheromone, becoming the dominant path for the colony.

ACO is a heuristic algorithm in which a colony of artificial ants works together to find good solutions to various static and dynamic optimization problems in discrete and continuous areas. It allocates IT resources to a series of relatively simple means (i.e. artificial ants) that communicate indirectly via a trace of pheromones. It is a multi-agent probabilistic algorithm that uses a probability distribution for the transition between iterations. However, the Ant algorithms are particularly effective in solving discrete combinatorial optimization problems. Their successful use in the continuous research space has been widely reported.

D. IEEE 9 bus system

The modified test system of the IEEE 9 bus consists of 3 synchronous machines with IEEE type 1 exciters. There are 12 buses, 6 transmission lines, 6 transformers and 3 constant impedance loads. The total load required is 315 MW and 115 MV Ar. In this single source, a hybrid solar wind system based on renewable energy has been replaced.

A photovoltaic system connected to the grid without accumulating backup energy is environmentally friendly and is often used by people because of the reduction in maintenance and costs. However, in the event of a power outage during the night or in cloudy weather, the system should stop operations until AC power is available. Photovoltaic systems connected to the grid with a backup ES are normally connected to the power grid. This configuration offers numerous advantages, for example the excess sale of photovoltaic electricity production to the grid, the recharging of the battery system during off-peak hours and the purchase of grid electricity to supply the loads when the photovoltaic energy and the battery is insufficient. Renewable photovoltaic sources cannot provide a constant energy supply and can lead to a potential imbalance in production and demand, especially during off-peak times when PV generates more energy and during peak times when load demand increases too much.

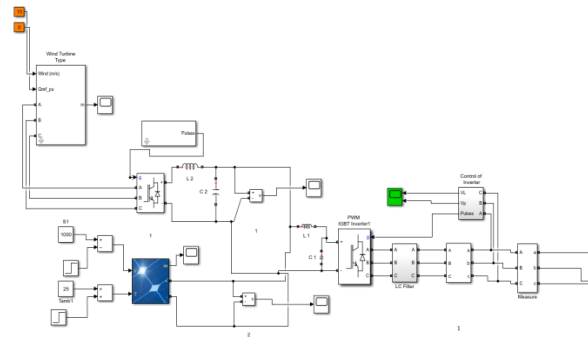

Fig. 2. Hybrid energy system

V. RESULTS

This work has described the implementation of SFCL in an IEEE 9 bus system. The coordination and control of the relay based in accordance with the SFCL operation is done by using various artificial intelligence based algorithms. This work has done a comparative analysis of the SFCL-relay operation with the particle swarm optimization (PSO) and ant colony optimization (ACO). The test system was created first to make the comparative analysis and then the best proposed algorithm based relay optimization control along with SFCL was implemented with the IEEE 9 bus system.

The chapter discusses the work on the basis of following

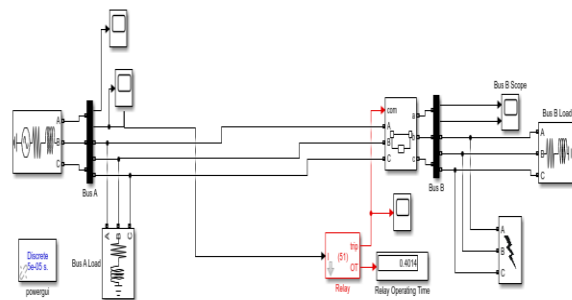

Fig. 3. Test system modeled without SFCL

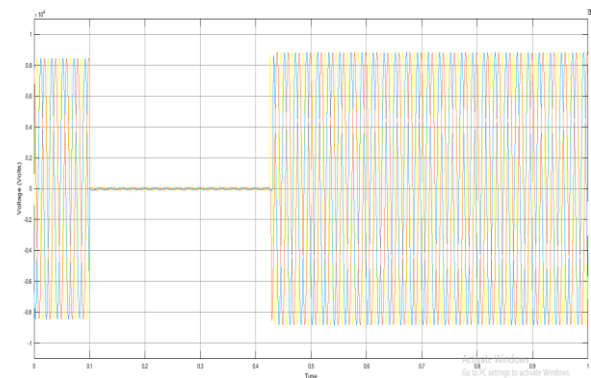

Fig. 4. Voltage output from the system having no SFCL

The figure shows the voltage output from the test system having no SFCL. The time at which fault occurs the voltage is reduced to 0 Volts zero from 9 KV. This will disconnect the power supply from the system completely. In order to overcome this problem we have used SFCL in the next models. The sudden disconnection of the sources from the grid highly undesirable. Superconducting fault current limiter (SFCL) based transient voltage stability scheme is presented for use in wind farms driven by doubly-fed induction generator (DFIG) during grid faults.

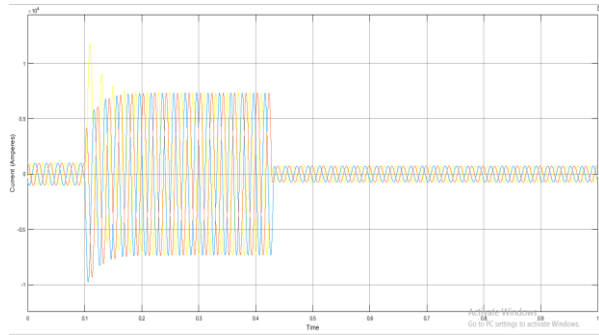

Fig. 5. Current output from the system having no SFCL

The figure shows the current output from the system having no SFCL. When the system is stimulated for one complete second and the fault is generated at 0.1 second in the test system we see that current Rises to a heavy value of approximately 6000 amperes. System Ability to remove this fault current is found to be 0.4014 seconds which means that system is able to recover from the fault after this operating time of the relay. The current is again reduced to approximately 80 amperes.

A. CASE 2: System modeled with SFCL and Relay circuit without AI technique.

In this system the source is connected to the load via a superfluous fault current limiter (SFCL). The relay breaker circuit is used to protect the load from the effect of heavy current flow when the fault occurs. The fault is created at 0.1 second while the simulation of the motor takes place for one second.

The system ability to recover from the fault is same as that of the test system in which no sfcl is used. However sudden disconnection of the supply from the grid can be avoided using this device.

To study the effect of sfcl in an system the voltage output and current output waveforms are being analyzed below

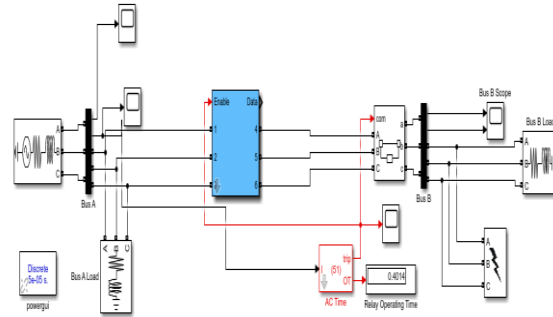

Fig. 6. System modeled with SFCL and Relay circuit without AI technique

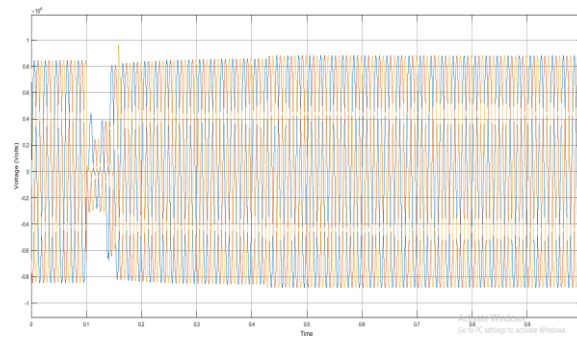

Fig. 7. Voltage output from the System modeled with SFCL and Relay circuit without AI technique

The figure shows the voltage output from the system in which no AI based technique is used for Relay but SFCL is used in the circuit. When the fault occurs the value of the voltage decreases abruptly however in a very short interval of time it starts recovering as during this time the current is dissipated in the Rsh of SFCL. As the fault current is reduced 0.4014 seconds the system resumes its actual operation.

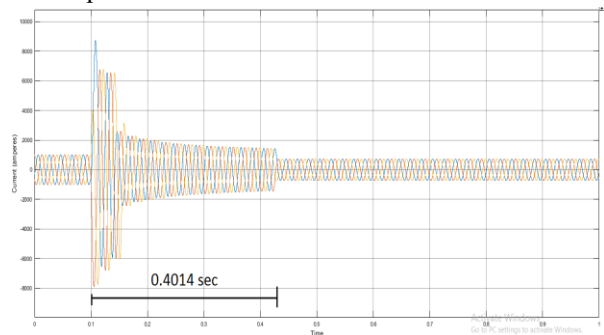

Fig. 8. Current output from the System modeled with SFCL and Relay circuit without AI technique

From this model it is concluded that both the operation time of the test system in case 1 and the test system in case 2 is same the voltage instead of getting 0 for the entire

time is has recovered to some value due to dissipation of the fault current in the sfcl. This model shows the advantage of using an sfcl in the grid system. Even if no AI technique is used it is still a better choice to prevent the system from disconnection during the fault from the source.

B. CASE 3: System modeled with SFCL and Relay circuit with PSO technique

The proposed method employs particle swarm optimization (PSO), an algorithm to search for optimal parameter settings such that the sensing time of the relay and SFCL dissipation is improved. The technique takes the fault current as input and optimizes the time by producing a duty cycle for SFCL operation. The voltage is expected to recover from the fault in a less time than the previous case which is produced at 0.1 seconds when the system is simulated for 1 second.

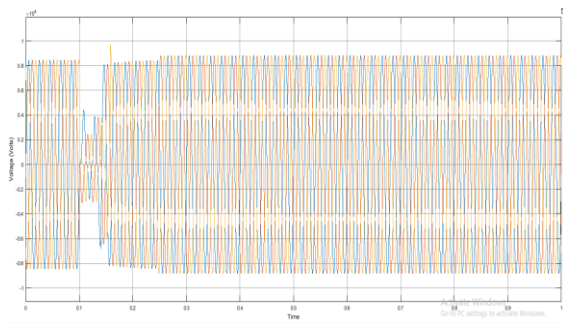

Fig. 9. Voltage output from the system modeled with SFCL and Relay circuit with PSO technique

The figure shows the voltage output from the system having relay controlled with particle Swarm Optimization technique for its co-ordination control and also improving the fault current detection sensitivity. Has been found that because of employing sfcl the voltage during the fault current does not reduces to zero and the system transient stability e is enhanced as it is able to recover from the fault in 0.22 seconds.

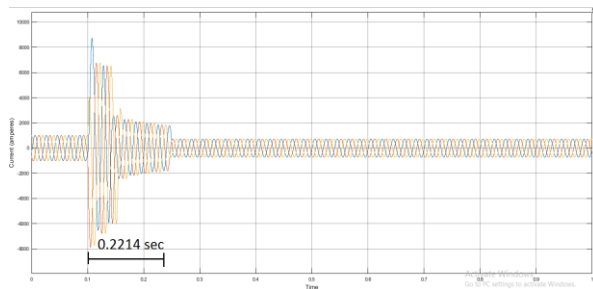

Fig. 10. Current output from the system modeled with SFCL and Relay circuit with PSO technique

The figure shows the current output from the system having PSO based control it has been found that current prices to high value of 6000 A at 0.1 seconds when the fault is created. However.

C. CASE 4: System modeled with SFCL and Relay circuit with ACO technique

This system uses ACO based optimization technique for its relay based operation. In this model sfcl is used for dissipation of current during fault time. The technique after optimization produces a duty cycle which operates SFCL and directs the current towards it.

This allows reduction in operating time and hence in a short period of time we can recover the voltage from the fault situation. Hence the system response towards the transient fault it is improved by using this optimization technique in the relay circuit.

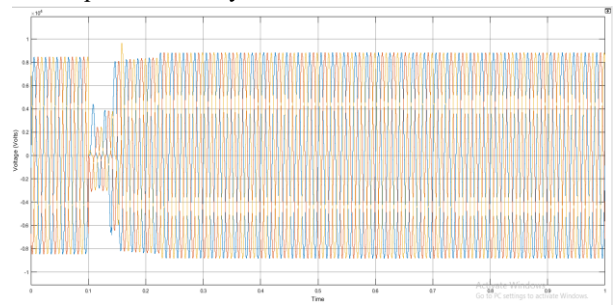

Fig. 11. Voltage output from the system modeled with SFCL and Relay circuit with ACO technique

The figure above is depicting the voltage output from the proposed ACO technique for the relay operation. The system voltage gets affected at 0.1 second when the fault is created and it starts rising slowly as the current is dissipated in the sfcl.

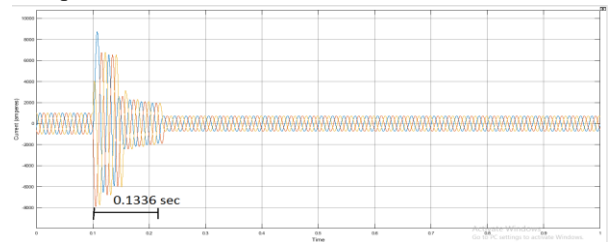

Fig. 12. Current output from the system modeled with SFCL and Relay circuit with ACO technique

The figure shows the current output from the system having ACO based Optimization control for the operation of relay in this condition it has been depicted that it takes about 0.133 seconds for the fault to get removed from the system. The current Rises to a higher amount at 0.1

seconds where the fault is created and it gets dissipated in the SFCL in a very short time due to this technique.

It can be concluded that it is very important to use sfcl in a good system in order to prevent the sources sudden voltage drop during the faults. The fault current is directed to sfcl so that it gets dissipated in it and the voltage is restored to its normal value. However when the relay breaker circuit control is subjected to a AI based technique which senses the fault current also reduces the operating time of the SFCL and relay circuit. During our research it was found that ant colony based proposed Optimization technique is found to be best for co-ordination control of the relays and sfcl based circuits. This technique is then implemented with IEEE 9 bus system for control of relays with SFCL.

D. Outputs with IEEE 9 bus system.

The IEEE 9 bus system is taken for analysis purpose in this work. The grid phase to phase voltage is 220KV. This grid system is fed by a hybrid renewable energy source giving a voltage output of 400V which is line to line voltage. This is then step up to be fed to the grid system via transformer.

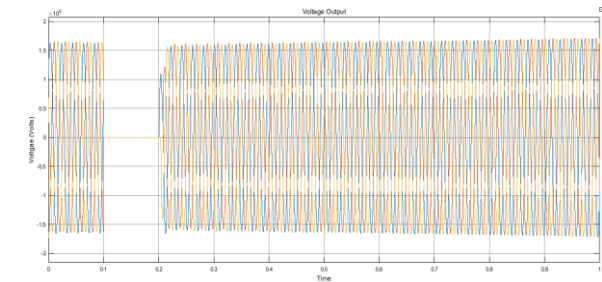

Fig. 13. Voltage output at the line where fault is generated in the grid system.

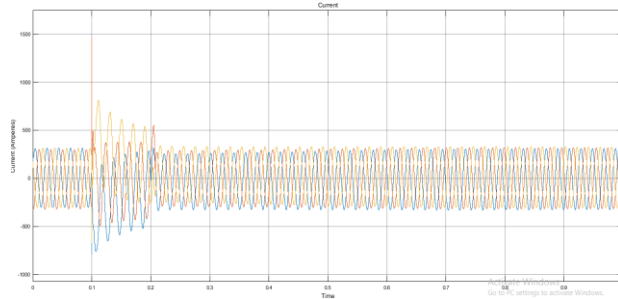

Fig. 14. Current output at the line where fault is generated

The voltage output of fault on the grid system. The fault is generated at 0.1 seconds when the grid system is simulated for 1 second. The fault at 0.1 seconds reduces the voltage to complete zero. The current rises to a high

value due to fault resulting in the reduction of voltage from 220KV to complete 0.

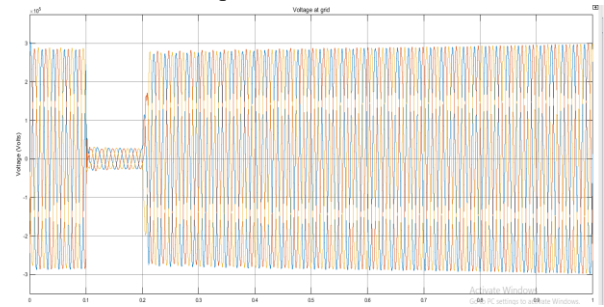

Fig. 15. Voltage at the grid connection terminal after using SFCL after step up from transformer

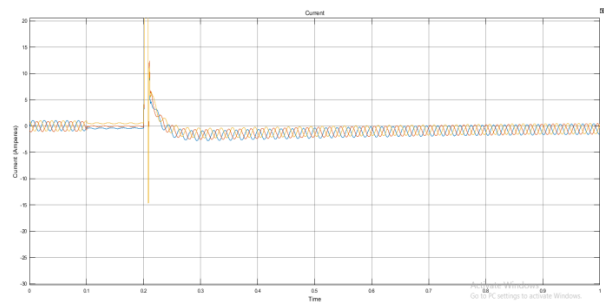

Fig. 16. Current at the grid connection terminal after using SFCL after step up from transformer

In this case the voltage output is studied at the point where the source I connected with the grid after stepping up its voltage from the transformer. The grid voltage was 220 KV phase to phase voltage.

It is clear that the fault current is dissipated in the SFCL circuit and the voltage has not reduced to complete zero. The voltage has reduced to 25KV approximately.

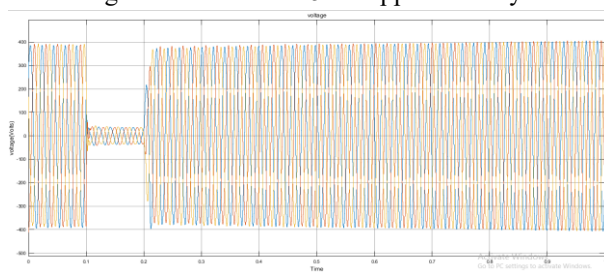

Fig. 17. Voltage at the renewable energy source terminal with SFCL.

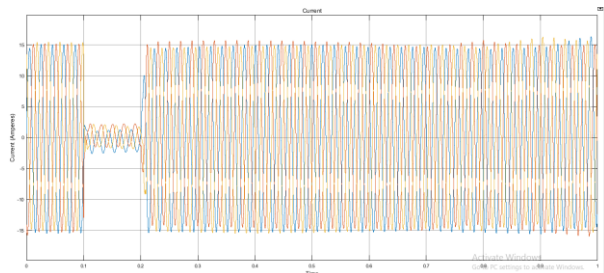

Fig. 18. Current at the renewable energy source terminal with SFCL

Then the voltage output is studied at the bus where the renewable energy source was during the local loads. The fault has occurred at the grid at 0.1 seconds. The SFCL is used to avoid sudden disconnection of the source from the grid.

The shows that the voltage doesn't come down to zero from 400 Volts, instead has reduced to approximately 100 Volts. The current is dissipated in the SFCL circuit and the voltage resumes its normal value along with the current. For final integration and coordination of relays in this IEEE 9 bus system the ACO control was used.

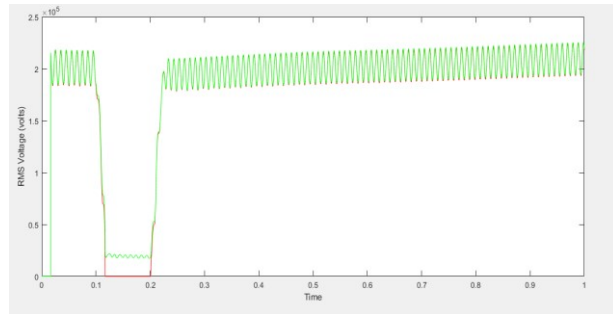

Fig. 19. Voltage output at the line where fault is created and voltage at the bus where source is integrated with the grid

The above comparative graph shows that the use of SFCL with the ACO based coordination control for relay has been beneficial. The voltage has been restored instead of getting completely zero due to the effect of fault.

The red graph depicts that the voltage at the grid was 220KV before the fault is created. But at 0.1 second the bus at which fault is created voltage drops to zero. However its effect is reduced at the bus where the renewable energy resource is connected to the grid by making use of SFCL controlled by relay having ACO control. The green graph shows that the voltage instead of getting completely zero has reduced to 25KV.

VI. CONCLUSION

The work has proposed resistive SFCL when a fault occurs in a simple high voltage (HV) power system (IEEE 9 bus system). To evaluate the impact of SFCL in the studied power system, time domain approach is used to evaluate the short-circuit current in the electrical power system and artificial based controlling techniques are being proposed to achieve the objective.

The work has done experiments on a test system and studied the effects of SFCL on it by changing the

controlling algorithms for fast sensing and mitigation of fault current in the relay circuit.

The following table concludes the work of the AI based techniques

Test System and Control algorithms	Operating time { seconds }
without SFCL	0.4014
with SFCL but without AI technique	0.4014
with SFCL and with PSO technique	0.2214
with SFCL and with proposed ACO technique	0.1336

The above results conclude the effectiveness of the proposed ACO based Optimization control for the operation of relay in accordance with SFCL in the circuit. The first two test system concludes that the system having SFCL reduces and fault current rise and prevents the voltage from dropping to zero even if no AI based technique is used and the operating time remains the same. The AI based techniques further reduces the operating time also thereby making the system more efficient as the voltage is restored to its normal value in a short interval of time when the test system is simulated for 1 second in MATLAB/SIMULINK environment. This system is then integrated with the IEEE 9 bus system having renewable energy resources.

VII. FUTURE SCOPE

Of course, the new type SFCL with different architecture is still under improvement. The work can be further integrated with different architecture for SFCL circuit and study its operation in those SFCL. The use of fast switching, forced commutated device like IGBT shunted with a variable resistance, can improve the performance of the system significantly during abnormal conditions. Further the enhancement of this design can lead to a better output and can make this system to work for low voltage ride through LVRT also.

REFERENCES

- [1] Alexandre Bitencourt, Henrique Koji "Technical and Operational Analysis of Fault Current Limiters" DOI: 10.18618/REP.2020.1.0061 March 2020.
- [2] Sankalpa Bohidar, Renu Sharma "Modeling of Resistive Type Superconducting Fault Current Limiter" International Journal of Engineering and Advanced Technology (IJEAT) ISSN: 2249 – 8958, Volume-8, Issue-6S3, September 2019.
- [3] Ahmed Hatata, A.S. Ebeid "Application of resistive super conductor fault current limiter for protection of grid-connected

- DGs” AEJ - Alexandria Engineering Journal vol. 57, issue 4. November 2018.
- [4] R. Haider, M. S. Zaman, “Modeling and Analysis of Resistive Type Superconducting Fault Current Limiters for Coordinated Microgrid Protection” Paper submitted to the International Conference on Power Systems Transients (IPST2017) in Seoul, Republic of Korea June 26-29, 2017.
- [5] Xiuchang Zhang, Harold S. Ruiz “Power flow analysis and optimal locations of resistive type superconducting fault current limiters” SpringerPlus volume 5, 14 November 2016.
- [6] Mrs. Kavya K.R, Mr. JoysunD’souza “A New Micro grid Fault Current Limiter for Transient Performance Improvement” JS DR | Volume 1, Issue 5, 2016.
- [7] Vaishnavi B V, AngelinSujji R S “Superconducting Fault Current Limiter & Its Application” International Journal of Scientific & Engineering Research, Volume 7, Issue 5, May-2016
- [8] O.Mahesh, G. Hari Krishna “Superconducting Fault Current Limiter For Energy Storage Protection Under Grounded Faults In A Micro Grid” International Research Journal of Engineering and Technology (IRJET). Volume: 02 Issue: 07 | Oct-2015.
- [9] Y. Zhang, and R. A. Dougal, “State of the Art of Fault Current Limiters and Their Applications in Smart Grid,” IEEE Conf in Power and Energy Society General Meeting, year 2012, pp.1-6.
- [10] S. Yadav, G. K. Choudhary, and R. K. Mandal, “Review on Fault Current Limiters,” International Journal of Engineering Research & Technology, Vol. 3, No. 4, pp. 1595–1603, 2014.