

Analysis on Fatigue Crack Initiation and Fatigue Crack Propagation in a Gear

Anand Mohan Singh
M.Tech. Scholar

Oriental Institute of Science and Technology
Bhopal, M.P., India

Mrs. Madhulata Sharma
Assistant Professor

Oriental Institute of Science and Technology
Bhopal, M.P., India

Abstract - An effective gear design balances strength, durability, reliability, size, weight and cost. Because of the advantage of gear, gearbox was used widely. But its fault also brought many losses of the production and society. It was necessary to research and analysis on the dynamical behavior of the gear system. The engineering structures may fail due to crack, which depends on the design and also on operating conditions in which it operates. It can be avoided by analyzing and understanding the manner in which it originates. It is necessary to develop design guidelines to prevent failure modes considering gear tooth fracture, by studying the crack propagation path in a gear. In variety of gear tooth geometry the crack propagation paths are predicted at various crack initiation location. The objective of this study was to follow the crack propagation in the tooth foot of a gear by the Finite Element Method (FEM). The study concludes with the analysis of available for standard gears, to highlight the different behavior in crack propagation. The influence of crack position and crack depth etc. on dynamic characteristics of gear has also been studied.

Keywords - Gear; Crack propagation path; Crack Growth; Fatigue; FEM;

I. INTRODUCTION

Gearbox is one of the most critical mechanical components in machineries, and condition monitoring of gearboxes is an important aspect of engineering maintenance in many industries such as manufacturing, aerospace, automotive and power industries. Gears are commonly used mechanical components in power transmissions and are frequently responsible for gearbox failures. They are generally design according to standards such as AGMA and DIN. Various types of gears have been developed to perform different functions, the most common of these being spur gears, helical gears, straight and spiral bevel gears, hypoid gears and planet gears. Gears can and do fail in service for a variety of reasons. In most cases, except for an increase in

noise level and vibration, total gear failure is often the first and only

indication of a problem. Many modes of gear failure have been identified, e.g. Fatigue, impact, wear or plastic deformation. Of these, one of the most common causes of gear failure is tooth bending fatigue. Two kinds of tooth damage can occur under repeated loadings that cause fatigue; namely, the pitting of gear teeth flanks and tooth fracture in the tooth root. Linear Elastic Fracture Mechanics (LEFM) as applicable to gear teeth has become increasingly popular, and it has been developed into a useful discipline for predicting the behavior of cracked gear teeth. The stress intensity factors are the key parameters necessary to estimate the characteristics of a crack. Analytical and numerical methods have been used to estimate gear tooth stress intensity factors.

Till today the most of the gears are failed because of crack growth at the root of gear. It is required to know the facts about gear failures. It is finding that different methods of Crack propagation analysis of gears are investigated by different research. Thus this research can give more information to industrial professionals and new researchers. Research in this field is continuously going on, and still some scope is there.

Gear is used to transmit force and motion from one shaft to another. The design and function of gears are closely associated, since gears are design for a specific function. The general types of failure modes in gear teeth include fatigue, impact, wear and plastic deformation, of these, the most common cause of gear failure is tooth bending fatigue. It is necessary that the gears should function properly without failure for particular applications and stipulated life cycles. The gear failure will cause partial or complete failure of the mechanical systems. The fracture mechanics approach is used for analysis of bending fatigue failure. It will predict the remaining useful life of gears due to crack propagation.

At present, in various kinds of engineering problem from mechanical industry, architectural industry and

microelectronic package, etc, cracks will appear because of the material's inherent flaw or the loads forced on the machine or equipment during the process of service [1]. Gearbox transmission system is one of most important parts of equipment, how significance to study the fault diagnosis of gearbox. Gearboxes provide speed and torque conversions from a rotating power source to another device at a desired ratio. They have been widely employed in automotive, aerospace, wind turbines and other industrial applications. Gear related failures comprise 60% of gearbox failures and 28% of helicopter failures occur because of a failure in the drive train of the gearbox [1]. Much research has been conducted on gear fault diagnosis and condition monitoring. Gear transmission is used most extensively in mechanical transmission. The gear will be taken place crack fault, fracture, vibration, and so on, when it is bearing load and transferring power. Therefore, it is necessary to research and analysis the behavior of kinematics and dynamics for gear system. It is well-known that there are significant challenges in the fault diagnosis of gears, often related to many uncertain factors.

The crack growth causes decrease in gear strength which affect the dynamic behaviour of gear transmission also bring out strong vibration and noise in gear system. In order to avoid the failure of gear system due to crack propagation it is necessary to diagnose gear crack in early stages using available methods. Normally, two approaches are followed: Analytical method and Finite Element Analysis (FEA). The widely used method by the researcher is FEA in which researcher have to build gear mesh models and calculate Gear Mesh Stiffness (GMS). Amongst these two methods FEA require sufficient mesh refinement and it is computationally expensive. On the other hand, an analytical method give satisfactory results and good agreement with FEA result with lower computational efforts.

II. RELATED WORK

The purpose of paper [1] was to verify, when using an oil debris sensor, that accumulated mass predicts gear pitting damage and to identify a method to set threshold limits for damaged gears. Using fuzzy logic techniques and the oil debris data, threshold limits were defined that discriminate between stages of pitting wear. Results indicate accumulated mass combined with fuzzy logic analysis techniques is a good predictor of pitting damage on spur gears.

Paper [2] describes that, Under increased power and higher speeds, gear wear and consequent fatigue failures are major concerns. For this reason, gear health monitoring has been the subject of intensive investigation and research. Vibration measurement and analysis is considered as the most general basis for gear fault detection. Several

methods have been proposed for detecting defects in gear systems. Wang, presented an evaluation of some of the emerging heavily contaminated by large background noise. Paper [3] deals with gear condition monitoring based on vibration analysis techniques. The detection and diagnostic capability of some of the most effective techniques are discussed and compared on the basis of experimental results, concerning a gear pair affected by a fatigue crack. The wavelet transform seems to be a good tool for crack detection; it is particularly effective if the residual part of the time-synchronous averaged signal is processed

In paper [4] The resonance demodulation technique has been extensively used for rolling bearing diagnostics. This paper presents a scheme of using the resonance demodulation technique for early detection of gear tooth cracks. The objective is to supplement the current techniques of gearbox fault diagnosis based on the synchronous signal averaging technique.

This paper [5] presents the use of vibration-based techniques in the early detection and advancement monitoring of distributed pitting fault. The pits were seeded on all of the gear tooth surfaces in differing degrees of severity, and intended to replicate the pitting damage due to misalignment. It has been found that presence of pitting fault cannot be clearly revealed by the conventional unless fault severity is significantly large.

This paper [6] demonstrates the use of vibration signature analysis procedures for health monitoring and diagnostics of a gear transmission system. The procedures used in this paper include the numerical simulation of the dynamics of a gear transmission system with single and multiple tooth damage, the application of the Wigner-Ville Distribution (WVD) and the Wavelet transform in damage identification and quantification of damaged tooth based on the numerically generated vibration signal.

Paper [7] Adhesive joints are in general subjected to combined normal and shearing stresses. Proceeding from the known constancy of fracture energy due to normal loading, it is shown that adhesive joints can be analyzed by utilizing the elastic analysis of non-homogeneous media in which the ratio of normal and shear stress appears as the important parameter. This dependence is determined by three separate experimental configurations.

Paper [8] describes the mechanical integrity of many electronic devices and their components is determined by the strength of the interfaces between dissimilar materials. Therefore, the knowledge of interfacial strength is important to the design for reliability of these devices. A few examples are die/die attach interface, lead frame /molding compound interface, and copper / resin interfaces in multilayer printed circuit boards.

In this paper [9], a new technique is introduced for the control of the far field and mixed-mode crack tip of a single lap shear specimen with a crack along the interface. The interfacial fracture toughness and phase angle were computed by using near tip displacement variables through the analytical energy release rate and phase angle expressions derived by the authors. The results show that the facilities and methodology used in the current study can indeed be proved to possess the ability to control the far field and the mixed-mode conditions at crack tip, and to efficiently perform the mixed-mode fracture test.

Paper [10] presents a framework for integrating models, simulation, and experimental data to diagnose incipient failure modes and prognosticate the remaining useful life of critical components, with an application to the main transmission of a helicopter. Although the helicopter example is used to illustrate the methodology presented, by appropriately adapting modules, the architecture can be applied to a variety of similar engineering systems. For experiments, vibration data were collected through a number of accelerometers mounted on the frame of the transmission gearbox.

In paper [11] Information on damage levels is useful for condition based preventive maintenance decision making. This paper applied a reported ordinal ranking algorithm to diagnose the pitting damage levels in a planet gear for the first time. Experiment results show that ordinal ranking can generate a good ranking model for damage level diagnosis. Comparisons with a classical classification method demonstrate the advantage of ordinal ranking.

In paper [12] One kind of gear fault was numerically simulated so that the influence of gear fault to change of vibration state was studied theoretically, and the symptom generated by faults was found. A finite element model with crack in gear roots was established with mixed meshing of singularity and isoparametric elements. The results were compared to that of simulation and theory, the validity of the theoretic and simulative was testified and the reliability was proved. There was important guidance for predicting the residual life of the gear with crack.

In this paper [13], delaminations between die attach and copper heat sink are analyzed by finite element analysis (FEA). Different sizes are considered to investigate how the crack propagates and the results show that the crack can easily propagate at first, but it would be a little more difficult and finally the crack is so long that there is little chance to propagate, if the crack growth is stable, or if the strain energy release rate gets smaller. Effect of interfacial delamination on thermal performance is also investigated and it is found that delaminations have a great impact on LED's thermal resistance.

Paper [14] has Fatigue Studies of SAC 305 solder samples in various geometries specific for microelectronic packaging has been performed [1–3]. However, there is a need to study the bulk material properties to further understand the performance of SAC 305 in a non-microelectronics setting. Some fatigue studies involving bulk solder have been conducted [4], but more work needs to be performed to completely understand the behavior of SAC 305

This paper [15] presents the crack initiation and propagation behavior in 4-point bending low cycle fatigue for four kinds of copper thin films used in electronic devices at room and 353K. There was a distinct difference in cycles to crack depending on the fabrication process but not on surface roughness. The crack propagation rates depended on the fabrication process of the films but surface roughness. Raising the testing temperature accelerated cycle to crack and cracks propagation rate.

Paper [17] studied, numerically and experimentally, the gear body rim thickness effect on the crack propagation direction in the teeth foot by using bidimensional finite element code FRANC (Fracture Analysis Code) for the simulation of the crack propagation. This analysis uses fracture mechanics with linear elasticity. A triangular finite element is used in the crack tip to represent the singularity of the constraint. The stress intensity factor is estimated and used to predict the crack propagation direction.

More recently, [18] analyzed the effect of gear rotation speed on the crack propagation direction.

Paper [19] describe an embedded modeling approach for identifying gear meshing stiffness from either measured gear angular displacement or transmission error. The embedded model integrated a physical based model of the gearbox and a parametric representation, in the form of truncated Fourier series, of meshing stiffness. A solution method is then used to find the meshing stiffness that minimizes the discrepancy between model output and measured output. Furthermore, an algorithm is also developed to estimate the size of tooth crack from the identified meshing stiffness. Both simulation and experimental studies were conducted to evaluate if the tooth meshing stiffness can effectively reveal a tooth crack and if the crack size can be estimated with an adequate level of accuracy.

In [20]-[21] author developed a survey using the finite element method to simulate, in quasi-static behavior, the stiffness of a toothed wheel couple. One of the gears may contain a crack, and they analyze the evolution of the stress intensity factor, according to the position of the contact point, on the profile of the pinion.

Paper [22] presents a model to determine the service life of a gear in fatigue in the presence of an initial crack in the

tooth foot. The finite element method is used to simulate the crack propagation based on linear elastic fracture mechanics and using the correlation displacement method to determine the relation between intensity factor and length of the crack. In [23] author presents a dynamic model with six degrees of freedom for a spur gear having cracks localized in the teeth feet. This model takes into account the slip between teeth in contact. They noted that the presence of a crack decreases the mesh stiffness and the modulation in the frequency spectrum.

III. FRACTURE MECHANICS

Failure of the engineering structures is caused by cracks, which is depending on the design and operating conditions that extend beyond a safe size. Cracks present to some extent in all structures, either as a result of manufacturing defects or localized damage in service. The crack growth leads to a decrease in the structural strength. Thus, when the service loading to the failure of the structure. Fracture, the final catastrophic event takes place very rapidly and is preceded by crack growth, which develops slowly during normal service conditions. Damage Tolerance (DT) assessment is a procedure that defines whether a crack can be sustained safely during the projected service life of the structure. DT assessment is therefore required as a basis for any fracture control plan, generating the following information upon which fracture control decision can be made: the effect of cracks on the structural residual strength, leading to the evaluation of their maximum permissible size, and the crack growth as a function of time, leading to the evaluation of the life of the crack to reach their maximum permissible size from safe operational life of the structure is defined.

Fracture mechanics has developed into a useful discipline for predicting strength and life of cracked structures. Linear elastic fracture mechanics can be used in damage tolerance analysis to describe the behavior of crack. The fundamental assumption of linear elastic fracture mechanics is that the crack behavior is determined solely by the values of the stress intensity factors which are a function of the applied load and the geometry of the cracked structure. The stress intensity factors thus play a fundamental role in linear elastic fracture mechanics applications. Fracture mechanics deals with the study of how a crack in a structure propagates under applied loads. It involves correlating analytical predictions of crack propagation and failure with experimental results. Calculating fracture parameters such as stress intensity factor in the crack region, which is used to estimate the crack growth, makes the analytical predictions. Some typical parameters are: Stress intensity factors in Open mode (K_I), Shear mode (K_{II}) and Tear mode (K_{III}) (as

shown in figure 1) and J-Integral: Path independent line integral that measures the strength of the singular stresses and strains near the crack tip (as shown in figure 2).

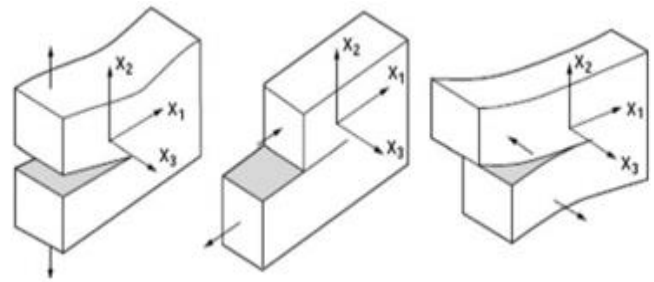
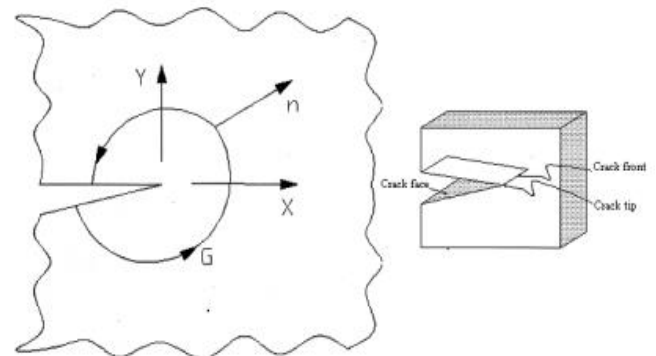

Figure 1: Three types of loading on a cracked body



G=integral path; N=crack direction; x, y=coordinates

Figure 2: J-integral, Crack tip and Crack face

Energy release rate is the amount of work associated with a crack opening or closure. The evaluation of the stress field around the crack tip to show that, for pure opening mode and in the limit of linear elastic fracture mechanics, the vanishing small fields fracture zone is surrounded by a linear elastic material with stress and strain fields uniquely determined, for any type of loading, geometry or structure size, by the stress intensity factor K_{I} . It flows that a critical value K_{IC} must exist so that when the actual K_I is lower, no crack growth can take place. This reasoning may be extended to other fracture mode to obtain fracture criteria. Hence, for pure shear mode and tear mode, critical stress intensity factors K_{IIC} , K_{IIIC} may be defined such that the crack growth may occur when the critical value are reached. But these parameters give only information for pure mode loadings, and do not allow following the cracking process, which in general involve change from pure to mixed modes. For mixed modes, the straight approaches consist that fracture may initiate the value of K_I , K_{II} , K_{III} a critical condition.

IV. FATIGUE FAILURE

Gears are often used in mechanical construction and serve to transmit a rotational motion from the driving shaft to the driven shaft. Gears are generally designed according to

standards [1–3] that define the two typical types of damage that occur in these components: pitting and fatigue fracture. The gears must support, in addition to the imperfections from fabrication and installation, defects that are generated during working such as spalling and pitting [16]. Cracks and fissures that may occur and cause rupture of the tooth by propagation are of special concern. The phenomenon of crack propagation in foot of gear teeth was the center of interest for much research concerning the mechanical and dynamic behavior of gears.

The complete process of fatigue failure of mechanical elements may be divided into the following stages [2–5]: (1) microcrack nucleation; (2) short crack growth; (3) long crack growth; and (4) occurrence of final failure. In engineering applications the first two stages are usually termed as “crack initiation period”, while long crack growth is termed as “crack propagation period”. An exact definition of the transition from initiation to propagation period is usually not possible. However, the crack initiation period generally account for most of the service life, especially in high-cycle fatigue, see Fig. 1. The complete service life of mechanical elements can than be determined from the number of stress cycles N_i required for the fatigue crack initiation and the number of stress cycles N_p required for a crack to propagate from the initial to the critical crack length, when the final failure can be expected to occur:

$$N = N_i + N_p \tag{i}$$

One of the most convenient representations of the fatigue crack growth is the Kitagawa–Takahashi plot of applied stress range required for crack growth, $\Delta\sigma$, against crack length, a , using logarithmic scales, as shown in Fig. 4a [6]. If the relation between the stress intensity range ΔK and the crack length a is used to describe the same diagram, it will be equally drawn as the form in Fig. 4b [7]. In the area of a constant value of threshold stress intensity range ΔK_{th} the linear elastic fracture mechanics (LEFM) can be used to analyze the fatigue crack growth. The threshold crack length a_{th} , below which LEFM is not valid, may be estimated approximately as [7]:

$$a_{th} \approx \frac{1}{\pi} \left(\frac{\Delta K_{th}}{\Delta \sigma_{FL}} \right)^2 \tag{ii}$$

Where, σ_{FL} is the fatigue limit, see Figs. 3 and 4. The threshold crack length a_{th} thus defines the transition point between short and long cracks, i.e. the transition point between initiation and propagation period in engineering applications.

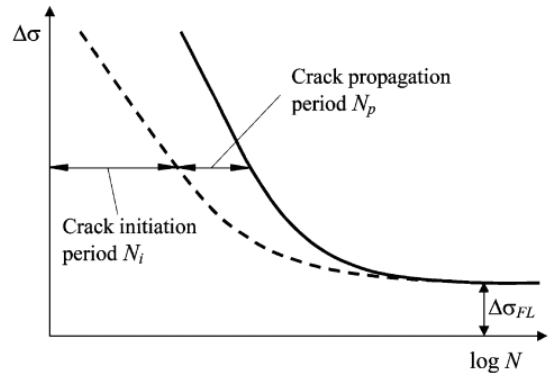

Figure 3: Schematic representation of the service life of mechanical elements.

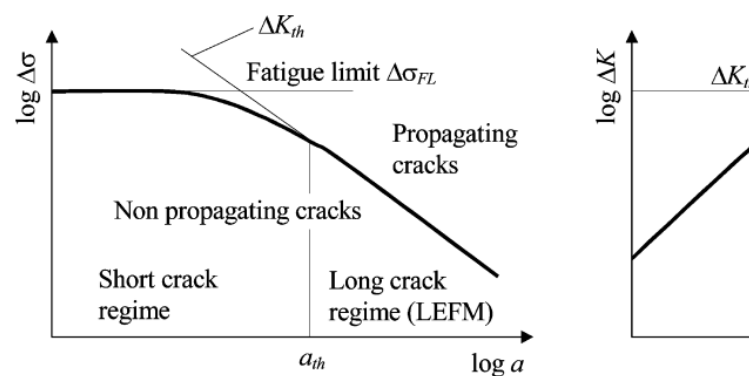

Figure 4: (a) Variation of the applied stress range with the crack length, (b) Variation of the stress intensity range with the crack length

A. Fatigue Crack Initiation

The initiation of fatigue cracks represents one of the most important stages in the fatigue process. Position and mode of fatigue crack initiation depends on the microstructure of a material, the type of the applied stress and micro- and macro-geometry of the specimen. The initiation phase of fatigue life in a virgin material is often assumed to constitute the growth of short cracks up to the size a_{th} (see Fig. 4), which is the transition length of short cracks into long cracks. The fatigue crack initiation includes the early development of fatigue damage [12] and is strongly dependent on the size scale of observation. For example, materials scientists are likely to consider the nucleation of flaws along persistent slip bands (PSB) as the initiation stage of fatigue damage, whilst mechanical engineers may associate the resolution of crack detection with the threshold for crack nucleation. Between this wide range of view-points lies a variety of failure mechanisms that are affiliated with the inception of microscopic flaws at grain boundaries, twin boundaries, inclusions, as well as microscopic and macroscopic stress concentration [13]. The model for the fatigue crack initiation presented here is based on the continuum mechanics approach, were it is

assumed that the material is homogeneous and isotropic, i.e. without imperfections or damages. Methods for the fatigue analyses are in that case usually based on the Coffin–Manson relation between deformations (ϵ), stresses (σ) and the number of loading cycles (N_i).

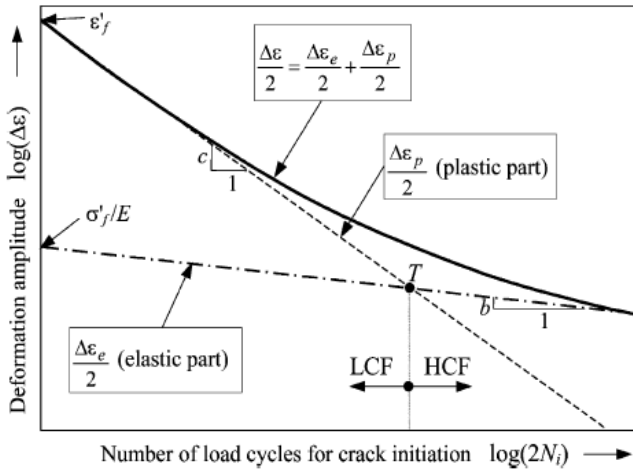

Figure 5: Strain-life (ϵ - N_i) method for the fatigue crack initiation

However, the strain-life method (ϵ - N_i) is usually used to determine the number of stress cycles N_i required for the fatigue crack initiation, where it is assumed that the crack is initiated at the point of the largest stresses in the material. The total cyclic strain range e comprises two components (elastic and plastic cyclic strain range $\Delta\epsilon_e$ and $\Delta\epsilon_p$) and can be described as:

$$\frac{\Delta\epsilon}{2} = \frac{\Delta\epsilon_e}{2} + \frac{\Delta\epsilon_p}{2} = \frac{\Delta\sigma}{2E} + \epsilon'_f \left(\frac{\Delta\sigma}{2\sigma'_f} \right)^{1/n'} = \frac{\sigma'_f}{E} (2N_i)^b + \epsilon'_f (2N_i)^c \quad (iii)$$

Where, $\Delta\sigma$ is the applied stress range, E is the Young's modulus, n' is the cyclic strain hardening exponent, σ'_f is the fatigue strength coefficient, ϵ'_f is the fatigue ductility coefficient, b is the exponent of strength and c is the fatigue ductility exponent, see Fig. 5. The number of stress cycles N_i required for the fatigue crack initiation can then be solved iterative from Eq. (3) for the applied stress range $\Delta\sigma$ and the appropriate material parameters E , n' , σ'_f , ϵ'_f , b and c .

It is known from the practical applications that the fatigue failures on gears are usually nucleated at the surface and so surface conditions become an extremely important factor influencing fatigue strength. Normally, scratches, pits, machining marks etc. influence fatigue strength by providing additional stress raisers which aid the process of crack nucleation. Broadly speaking, high strength steels are more adversely affected by a rough surface finish than softer steels. Therefore, the influence of surface finish on fatigue strength is strongly related to tensile strength of the material. The surface finish correction factor C_{sur} is

presented in Fig. 6 in dependence on surface roughness R_a and tensile strength of the material R_m [24]. Using this assumption the real service life of gears may be reduced in regard to the appropriate value of C_{sur} , which is, in the present study, considered through the following equation:

$$\Delta\sigma_{FLr} = \Delta\sigma_{FL} C_{sur} \quad (iv)$$

where $\Delta\sigma_{FLr}$ is the real fatigue limit and $\Delta\sigma_{FL}$ is the fatigue limit of the polished laboratory specimen.

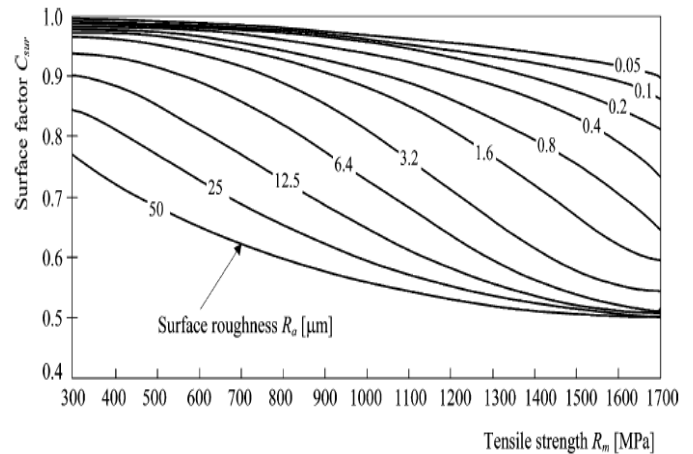

Figure 6: Surface finish correction factor

B. Fatigue Crack Propagation

The application of LEFM to fatigue is based upon the assumption that the fatigue crack growth rate, da/dN , is a function of the stress intensity range $\Delta K = K_{max} - K_{min}$, where a is a crack length and N is a number of loading cycles. In this study the simple Paris equation is used to describe of the crack growth rate [24]:

$$\frac{da}{dN} = C [\Delta K(a)]^m \quad (v)$$

Where, C and m are the material parameters. In respect to the crack propagation period N_p according to Eq. (1), and with integration of Eq. (5) one can obtain the number of loading cycles N_p :

$$\int_0^{N_p} dN = \frac{1}{C} \int_{a_{th}}^{a_c} \frac{da}{[\Delta K(a)]^m} \quad (vi)$$

Eq. (6) indicates that the required number of loading cycles N_p for a crack to propagate from the initial length a_{th} to the critical crack length a_c can be explicitly determined, if C , m and $\Delta K(a)$ are known. C and m are material parameters and can be obtained experimentally, usually by means of a three point bending test as to the standard procedure ASTM E 399-80. For more complicated geometry and loading cases it is necessary to use alternative methods. In the Finite

Element Method the determination of the stress intensity factor is based on the displacement correlation method using singular quarter-point, six node triangular elements around the crack tip, Fig. 7. The stress intensity factor in mixed mode plane strain condition can then be determined from the nodal displacements as:

$$K_I = \frac{2G}{(3-4\nu) + 1} \sqrt{\frac{\pi}{2L}} [4v_d - v_e - 4v_b + v_c];$$

$$K_{II} = \frac{2G}{(3-4\nu) + 1} \sqrt{\frac{\pi}{2L}} [4u_d - u_e - 4u_b + u_c]$$
(vii)

Where, G is the shear modulus of the material, ν is the Poisson ratio, L is the finite element length on crack face, u and v are displacements of the finite element nodes b, c, d and e, see Fig. 7. The combined stress intensity factor is then:

$$K = \sqrt{(K_I^2 + K_{II}^2) \cdot (1-\nu^2)}$$
(viii)

The computational procedure is based on incremental crack extensions, where the size of the crack increment is prescribed in advance. In order to predict the crack extension angle the maximum tangential stress criterion (MTS) is used. In this criterion it is proposed that crack propagates from the crack tip in a radial direction in the plane perpendicular to the direction of greatest tension (maximum tangential tensile stress). The predicted crack propagation angle (see Fig. 7) can be calculated by:

$$\theta_0 = 2 \tan^{-1} \left[\frac{1}{4} \frac{K_I}{K_{II}} \pm \sqrt{\left(\frac{K_I}{K_{II}} \right)^2 + 8} \right]$$
(viii)

A new local remeshing around the new crack tip is then required. The procedure is repeated until the stress intensity factor reaches the critical value K_c , when the complete tooth fracture is expected. Following the above procedure, one can numerically determine the functional relationship $K=f(a)$.

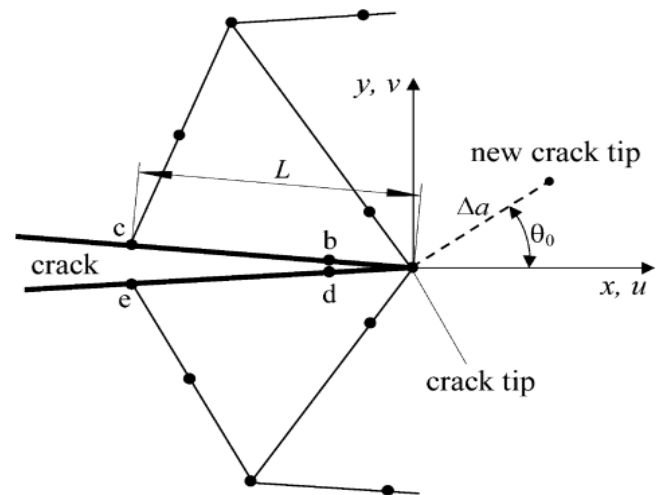

Figure 7: Triangular quarter-point elements around crack tip

V. CONCLUSION

The paper presents a study of service life of gears in bending fatigue in a gear tooth root. The effect of crack dimension and the direction of crack propagation, in the teeth foot, on the mesh stiffness is studied. This research paper enables the user to determine the whole service life, given adequate fatigue material parameters. The crack initiation period is based on a stress-strain analysis using the FEM, where it is assumed that the crack is initiated at the point of maximum principal stress in a gear tooth root. Therefore, the model can be improved with additional theoretical and numerical research, although additional experimental results will be required to provide the required material parameters. This task will be left for future investigation.

REFERENCES

- [1] P. J. Dempsey, "Gear damage detection using oil debris analysis," in 14th International Congress and Exhibition on Condition Monitoring and Diagnostic Engineering Management Manchester, UK, 2001.
- [2] S. J. Loutridis, "Gear failure prediction using multiscale local statistics," *Engineering Structures*, vol. 30, pp. 1214-1223, 2008.
- [3] G. Dalpiaz, A. Rivola, and R. Rubini, "Effectiveness and sensitivity of vibration processing techniques for local fault detection in gears," *Mechanical Systems and Signal Processing*, vol. 14, pp. 387-412, 2000.
- [4] W. Wang, "Early detection of gear tooth cracking using the resonance demodulation technique," *8/8 Mechanical Systems and Signal Processing*, vol. 15, pp. 887-903, 2001.
- [5] H. Ozturk, I. Yesilyurt, and M. Sabuncu, "Detection and advancement monitoring of distributed pitting failure in gears," *Journal of Nondestructive Evaluation*, vol. 29, pp. 63-73, 2010.

- [6] F. K. Choy, D. H. Mugler, and J. Zhou, "Damage identification of a gear transmission using vibration signatures," *Journal of Mechanical Design*, vol. 125, pp. 394–403, 2003.
- [7] B. M. Malyshev, , and R. L. Salganik, 1965, "The Strength of Adhesive Joints Using the Theory of Cracks," *Int. J. Fract. Mech.*, 1, pp. 114–128.
- [8] S. Liu, Y. Mei, and T. Y. Wu, "Bi-material Interfacial Crack Growth as a Function of Mode-mixity," *IEEE Trans. Compon., Packag., Manuf. Technol.*, vol. 18, no. 3, pp. 618–626, Sep. 1995.
- [9] J. Wang, M. Lu, W. Ren, D. Zou, and S. Liu, "A Study of the Mixed-mode Interfacial Fracture Toughness of Adhesive Joints Using a Multi-axial Fatigue Tester," *IEEE Trans. Electron. Packag. Manuf.*, vol. 22, no. 2, pp. 166–173, Apr. 1999.
- [10] R. P. Aldaco. A Model Based Framework for Fault Diagnosis And Prognosis of Dynamical Systems With An Application To Helicopter Transmission. Ph.D. Dissertaion, Georgia Institute of Technology, 2007.
- [11] Xiaomin Zhao; Ming J Zuo; Zhiliang Liu, Diagnosis of pitting damage levels of planet gears based on ordinal ranking, 2011 IEEE Conference on Prognostics and Health Management.
- [12] Jinfeng Hao; Jianshe Kang; Jingfei Li; Zhining Zhao, A Physical Model based research for fault diagnosis of gear crack, 2012 International Conference on Quality, Reliability, Risk, Maintenance, and Safety Engineering.
- [13] Xiang Gao; Xin Wu; Yong Xu; Sheng Liu, Analyses of propagation behavior of crack at interface between die-attach and Cu base and cracks' effects on reliability of high brightness light-emitting diode (LED), IEEE, 2013.
- [14] Gary Paradee; Aris Christou, "Fatigue behavior and effect of crack propagation in lead free solder in microelectronic packaging", International Semiconductor Device Research Symposium, 2009.
- [15] Tasuku Kambayashi; Masao Sakane; Kenji Hirohata, "Low cycle fatigue crack initiation and propagation behavior of copper thin films used in electronic devices", IEEE CPMT Symposium Japan, 2012.
- [16] Spievak, E., et al.: Simulating Fatigue Crack Growth in Spiral Bevel Gears. Cornell Fracture Group, Cornell University, Ithaca, NY 14853 (Aug 2000)
- [17] Lewicki, D., et al.: Rim Thickness Effects on Gear Crack Propagation Life. Vehicle Propulsion Directorate, U.S. Army Research Laboratory, NASA Lewis Research Center, Cleveland, OH, 44135 (Aug 2006).
- [18] Lewicki, D.: Effect of Speed (Centrifugal Load) on Gear Crack Propagation. U.S. Army Research Laboratory, Glenn Research Center, Cleveland, OH (Aug 2001).
- [19] Li, C.J., Lee, H.: Gear fatigue crack prognosis using embedded model, gear dynamic model and fracture mechanics. Department of Mechanical, Aerospace, and Nuclear Engineering, Rensselaer Polytechnic Institute, Troy, NY 12180 (June 2004)
- [20] Sfakiotakis V.G., Anifantis N.K.: Finite element modeling of spur gearing fractures. Machine Design Laboratory, Mechanical & Aeronautics Engineering Department, University of Patras, Gr- 26500, Patras Greece (Oct 2001).
- [21] Glodez S., et al.: A computational model for determination of service life of gears. Faculty of Mechanical Engineering, University of Maribor, P.O. Box 224, Smetanova ul. 17, 2000 Maribor, Slovenia (Feb 2002)
- [22] Kramberger, J., et al.: Computational model for the analysis of bending fatigue in gears. University of Maribor, Faculty of Mechanical Engineering, Smetanova 17, SI-2000 Maribor, Slovenia (July 2004)
- [23] Howard, I.H., et al.: The dynamic modeling of a spur gear in mesh including friction and a crack. *Mech. Sys. Signal Process.* 15(5), 831–853 (2001).
- [24] Ewalds HL, Wanhill RJ. *Fracture mechanics*. London: Edward Arnold Publication, 1989.