

Study on Hybrid Systems, Grid Integrated Based on Renewable Energy Systems Driving Local Loads

Sanjeev Jarariya

Assistant Professor

Dept of Electrical & Electronics Engineering
Corporate Institute of Science & Technology
Bhopal, M.P, India
sanjeevjarariya@gmail.com

Satyam Kumar Prasun

M.Tech Scholar

Dept of Electrical & Electronics Engineering
Corporate Institute of Science & Technology
Bhopal. M.P, India
prasun.satyam@gmail.com

Abstract: *The demand for electricity power is increasing day by day, which cannot be met with the satisfied level without non-renewable energy resource. Renewable energy sources such as wind, solar are universal and ecological. These renewable energy sources are best options to fulfill the world energy demand, but unpredictable due to natural conditions. The use of the hybrid solar and wind renewable energy system like will be the best option for the utilization these available resources. The objective of this paper is to study the various aspects of hybrid solar and wind system. The application and different theories related to the development of hybrid also discussed in this paper.*

Keywords: *Solar energy, Hybrid system, Wind energy*

1. INTRODUCTION

Small-scale renewable energy systems are becoming more popular due to the recent development of small-scale energy technologies and global increasing of the energy demand. Integration of these different technologies forming a hybrid system can be a realistic alternative to conventional fossil fuel powered engines to provide energy in small communities. Among these energy systems the renewable ones, such as wind, solar and biomass are even more attractive due to rising fossil fuel prices and environmental impacts [1, 2].

The combinations of different types of renewable energy such as wind, solar and biomass coupled with energy storage units, such as batteries and gas/diesel engines as backup, provide a stand-alone energy system usually called Remote Hybrid Power System (RHPS) [3, 4, 5].

Maintaining a stable system, supplying electricity with high quality, load sharing, reliability, flexibility, expandability, and system efficiency are the challenges in providing a robust SHRES. These technical challenges can be mitigated by suitable control strategies and an appropriate interfacing configuration of the system sources.

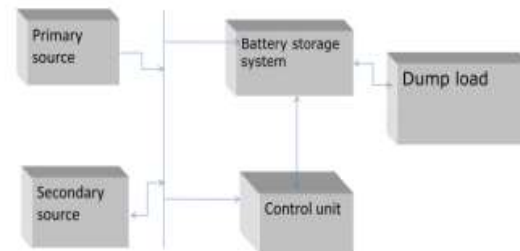

Figure 1: Example of HRE System

2. BASIC CONFIGURATION OF A STANDALONE HYBRID RENEWABLE ENERGY SYSTEM (SHRES)

This SHRES integrates PV, wind turbine and battery energy storage sources. These sources are connected separately to the three phase common AC bus through appropriate power electronic converters to achieve the desired conversion. The PV is interfaced through a VSI to invert the DC output voltage generated by the PV panels. The wind turbine is equipped with a variable speed direct drive permanent magnet synchronous generator (PMSG). The PMSG is more suitable for standalone applications because it does not require an AC excitation source for initial operation. However, the amplitude and frequency of the three-phase AC voltage generated by the PMSG fluctuates as the wind speed

varies. Therefore, appropriate power electronic converters are required to connect the wind source. Connecting the wind source via a three-phase diode rectifier does not require any additional controllers to regulate the fluctuating frequency and significantly reduces the overall switching losses of the wind energy conversion system. The battery energy storage is interfaced through a bidirectional VSC that works either in the rectification mode to convert the AC voltage from the common AC bus or in the inversion mode to invert the DC output voltage from the battery bank.

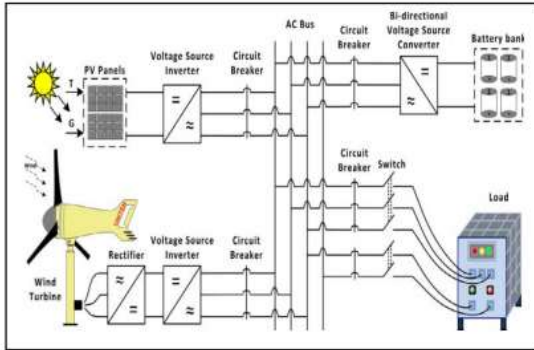

Figure 2. Basic configuration of the SHRES

2. LITERATURE SURVEY

Chandragupta Mauryan K.S et al.[1] Nowadays Renewable Energy plays a great role in power system around the world. It is a demanding task to integrate the renewable energy resources into the power grid. The integration of the renewable resources use the communication systems as the key technology, which play exceedingly important role in monitoring, operating, and protecting both renewable energy generators and power systems. This paper presents about the integration of renewable energy mainly focused on wind and solar to the grid.

[2] The paper reviews the current state of the design and operation of stand-alone PV-diesel hybrid energy systems. It highlights future developments, which have the potential to increase the economic competitiveness of such systems and their acceptance by the user. The continuous decline of costs for renewable energy technology, together with the establishment of a mature alternative energy industry, has led to the increased utilisation of renewable energy sources for remote area power generation. Rural households in industrialised and less developed countries attach high value to a reliable supply of electricity even if its capacity is limited.

[3] A complete set of match calculation methods for optimum sizing of PV/wind hybrid system is presented. In this method, the more accurate and practical

mathematic models for characterizing PV module, wind generator and battery are adopted; combining with hourly measured meteorologic data and load data, the performance of a PV/wind hybrid system is determined on a hourly basis; by fixing the capacity of wind generators, the whole year's LPSP (loss of power supply probability) values of PV/wind hybrid systems with different capacity of PV array and battery bank are calculated, then the trade-off curve between battery bank and PV array capacity is drawn for the given LPSP value; the optimum configuration which can meet the energy demand with the minimum cost can be found by drawing a tangent to the trade-off curve with the slope representing the relationship between cost of PV module and that of the battery.

[4] A techno-economic study to design a hybrid solar photo-voltaic-wind domestic power generating system for a site on the western coast of India is described. The system uses short-term electrical power storage using lead-acid batteries, and auxiliary power from the A.C. mains power supply.

The optimum system would be able to supply 84.16% of the annual electrical energy requirement of the site. In the last decades, engineers have turned towards artificial intelligence techniques in order to ensure continuous power flow. Many artificial intelligence techniques have been adapted to LFC with Fuzzy Logic and Artificial Neural Network (ANN) being the most common ones. Even a combination of these two intelligent techniques to form a hybrid Neuro-Fuzzy controller has been adapted to power systems

3. THE REACTIVE POWER AND VOLTAGE CONTROL

3.1. The Q(U) control

The Q(U) control strategy determines the reactive power of DG inverter according to the voltage at the grid-connected point, as shown in Fig. 2(a). The DG inverter absorbs reactive power when the voltage of grid-connected point is lower than UL. While the DG inverter injects reactive power when the voltage of grid-connected point is higher than the UU. UL and UU represent the lower and upper segmented voltage threshold, respectively. As well as, the reactive power of DG inverter is limited by the maximum reactive capacity of DG inverter.

3.2 Fuzzy control

The Fuzzy Logic controller performs similar tasks as a human operator by adjusting the input variables just by looking at the output of the plant (Altas and Neyens 2006). The four processes of the Fuzzy Logic system

are: fuzzification, rule base set up, decision-making by means of an inference mechanism and defuzzification.

optimum control system can be designed for system integrated with diesel engine also.

3.3 ANN

An artificial neural network (ANN) may be considered as a function approximator. The ANN architecture of Fig.2 described the way a neural network works to perform the required control action by approximating the unknown function. The parameters of the network must be adjusted so that the same output is obtained at both the unknown function output and the network output, provided that both systems experienced the same input. In this direction, any error in the system will be eliminated.

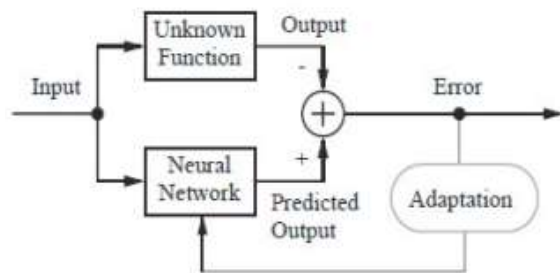

Figure 3. ANN architecture

3.4 Use of the SeBR(Series banking resistor)

the use of the SeBR to enhance transient stability in the case of severe three-phase faults in power plant substation busbars, cleared with a delay. For such contingencies, power system performance standards regarding stability margin have to be met. An adequate SeBR application to enhance the transient stability of a power system requires selecting: (i) optimal location of the SeBR in the power system from the application point of view, (ii) parameters of the resistor, (iii) the algorithm to control the SeBR switching off. Research results regarding the impact of the FCL location on transient stability enhancement can be found in [7,8,9]. The general idea of the SeBR application is to guarantee its connection to the circuit as soon as a critical contingency is detected

4. PROPOSED WORK

The paper has discussed various methodologies that has been recently applied for power enhancement in the renewable hybrid system. Any of these methodologies can be implemented with the power enhancement devices or inverter. Also the literature has discussed the system with diesel engine connected to the grid. The

5. CONCLUSION

The use of solar-wind hybrid renewable energy system is ever-increasing day by day and has shown incredible development in last few decades for electricity production all over the world. By using this development of new technologies and researches in the field of solar wind hybrid renewable energy system, a new difficulty arises, which become much more easily solved with new techniques. The presented review paper reported the different techniques and ideas about the HRES and its energy utilization

REFERENCES

- [1] P. Nema, R. Nema and S. Rangnekar, "A current and future state of art development of hybrid energy system using wind and PV-solar: A review," *Renewable and Sustainable Energy Reviews*, Vol. 13, No. 8, p. 2096–2103, 2009.
- [2] B. Wichert, "PV-diesel hybrid energy systems for remote area power generation — A review of current practice and future developments," *Renewable and Sustainable Energy Reviews*, Vol. 1, No. 3, p. 209–228, 1997.
- [3] B. Ai, H. Yang b, H. Shen a and X. Liao c, "Computer-aided design of PV/wind hybrid system," *Renewable Energy*, Vol. 28, No. 10, p. 1491–1512, 2003.
- [4] A. Bhave, "Hybrid solar-wind domestic power generating system—a case study," *Renewable Energy*, Vol. 17, No. 3, p. 355–358, 1999.
- [5] Chandragupta Mauryan.K.S, Nivethitha.T, Yazhini.B, Preethi.B, "Study on Integration of Wind and Solar Energy to Power Grid", *Nivethitha.T et al Int. Journal of Engineering Research and Application*, Vol. 4, Issue 5(Version 1), May 2014.
- [6] Sadi MAH, Ali MH. A fuzzy logic controlled bridge type fault current limiter for transient stability augmentation of multi-machine power system. *IEEE Trans Power Syst* 2016;31(1):602–11.
- [7] Sokolovsky V, Meerovich V, Vajda I. Transient stability of a power system with superconducting fault current limiters. *Period Polytech Elect Eng* 2017;51:3–9.
- [8] Almeida ME, Rocha CS, Dente JA, Costa Branco PJ. Enhancement of power system transient stability and power quality using superconducting fault current limiters. *2009 International Conference On Power Engineering, Energy And Electrical Drives*. 2009